

73DS

74DS

77DS

2 1/2"-6" | DN65-DN150
CLASS 150/300/PN 16

Dual Safe | Double Block & Bleed Floating Ball Flanged

Valve dimensions

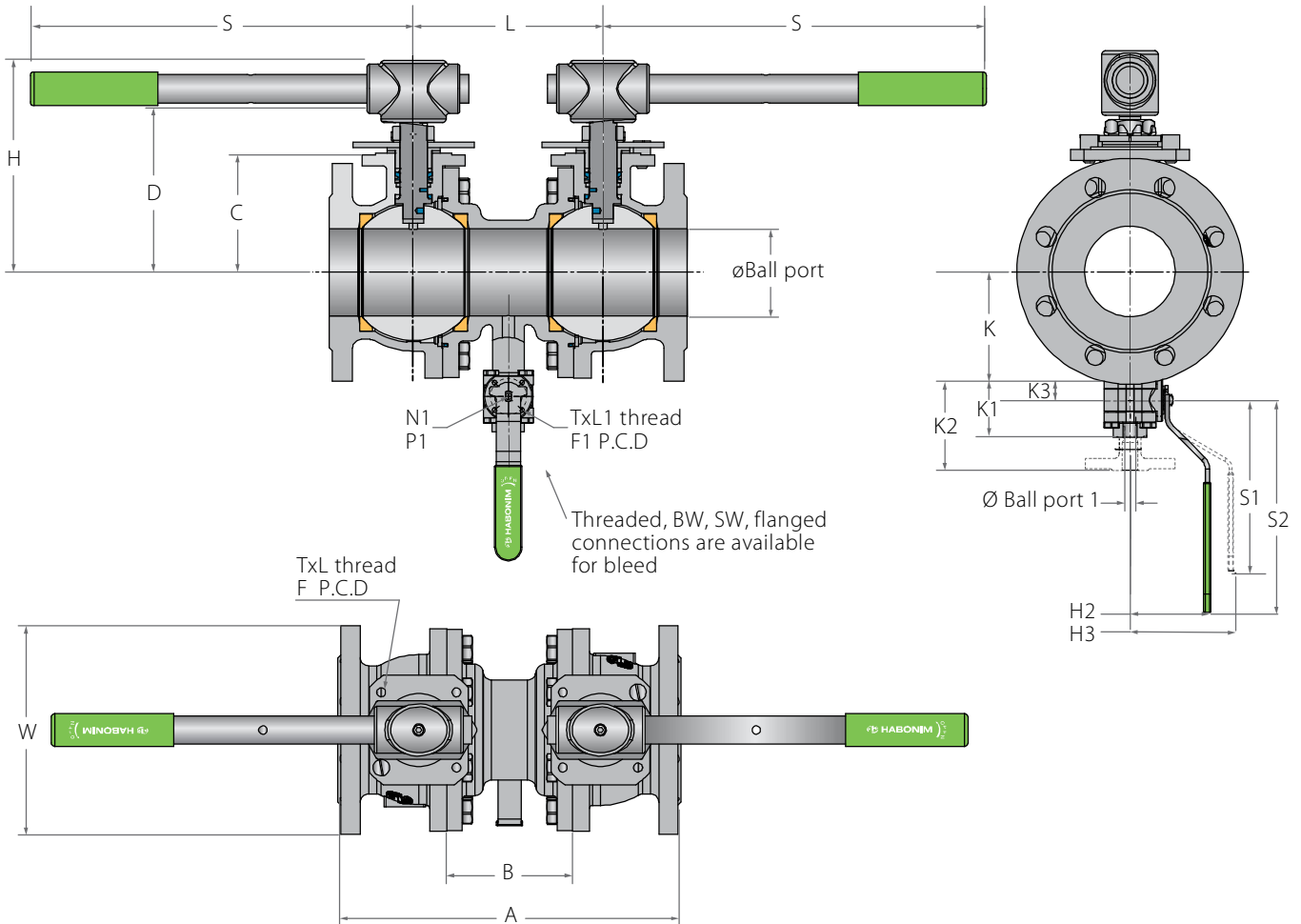

Bore dimensions

Std. port	Unit	Ball Port	A			B	C_73/74	D_73/74	H	K	L	S	W		W_16/40	N	P	F	TxL	Kv
			150	300	PN								150	300						
DN65	mm	65	375	400.5	349	155	119.00	165.5	184.5	90	209	288.1	180	190	185	1"-14	16.7 (F10)	102	M10X20	6.9
2 1/2"	inch	2.55	14.71	15.71	13.69	6.08	4.67	6.49	7.24	3.53	8.2	11.30	7.08	7.48	7.28	UNF-2A"	0.65	4.00		8
DN80	mm	80	369	406.8	369	160	108.00	154.5	194.9	95	214	350	191	210	200	1"-14	16.7 (F10)	102	M10X20	10
3"	inch	3.14	14.47	15.95	14.47	6.27	4.24	6.06	7.64	3.73	8.39	13.73	7.52	8.27	7.87	UNF-2A"	0.65	4.00		12
DN100	mm	100	442	482	442	215	124.00	170.5	210.9	115	273	350	230	254	225	1"-14	16.7 (F10)	102	M10X20	28
4"	inch	3.92	17.33	18.9	17.33	8.43	4.86	6.69	8.27	4.51	10.71	13.73	9.06	10.00	8.86	UNF-2A"	0.65	4.00		32
DN150	mm	150	681	703.2	681	280	179.00	248.4	302.2	165	354.00	846.5	279.4	328	328	1 "-12	26.2 (F12)	125	M16X30	49
6"	inch	5.88	26.71	27.58	26.71	10.98	7.02	9.74	11.85	6.47	13.88	33.20	11.00	12.91	12.91	UNF-1A"	1.03	4.90		57

Bleed dimensions

Std. port	Unit	Ball Port 1	K1	K2	K3	S1	S2	H2	H3	N1	P1	F1	TxL
DN20	mm	17.5	57.15	98.15	21.9	114.5	152.5	93	49	3/8 UNF	6.65	(F03)	36
3/4"	inch	0.69	2.24	3.85	0.86	4.51	6	3.66	1.93		0.26		1.41
DN25	mm	23.5	74.85	110.75	28.2	146	163	106	62	7/16 UNF	7.4	(F04)	42
1"	inch	0.92	2.94	4.34	1.11	5.75	6.42	4.17	2.44		0.29		1.65

73DS

74DS

77DS

2 1/2"-6" | DN65-DN150
CLASS 150/300/PN 16

Dual Safe | Double Block & Bleed Floating Ball Flanged

Components & materials

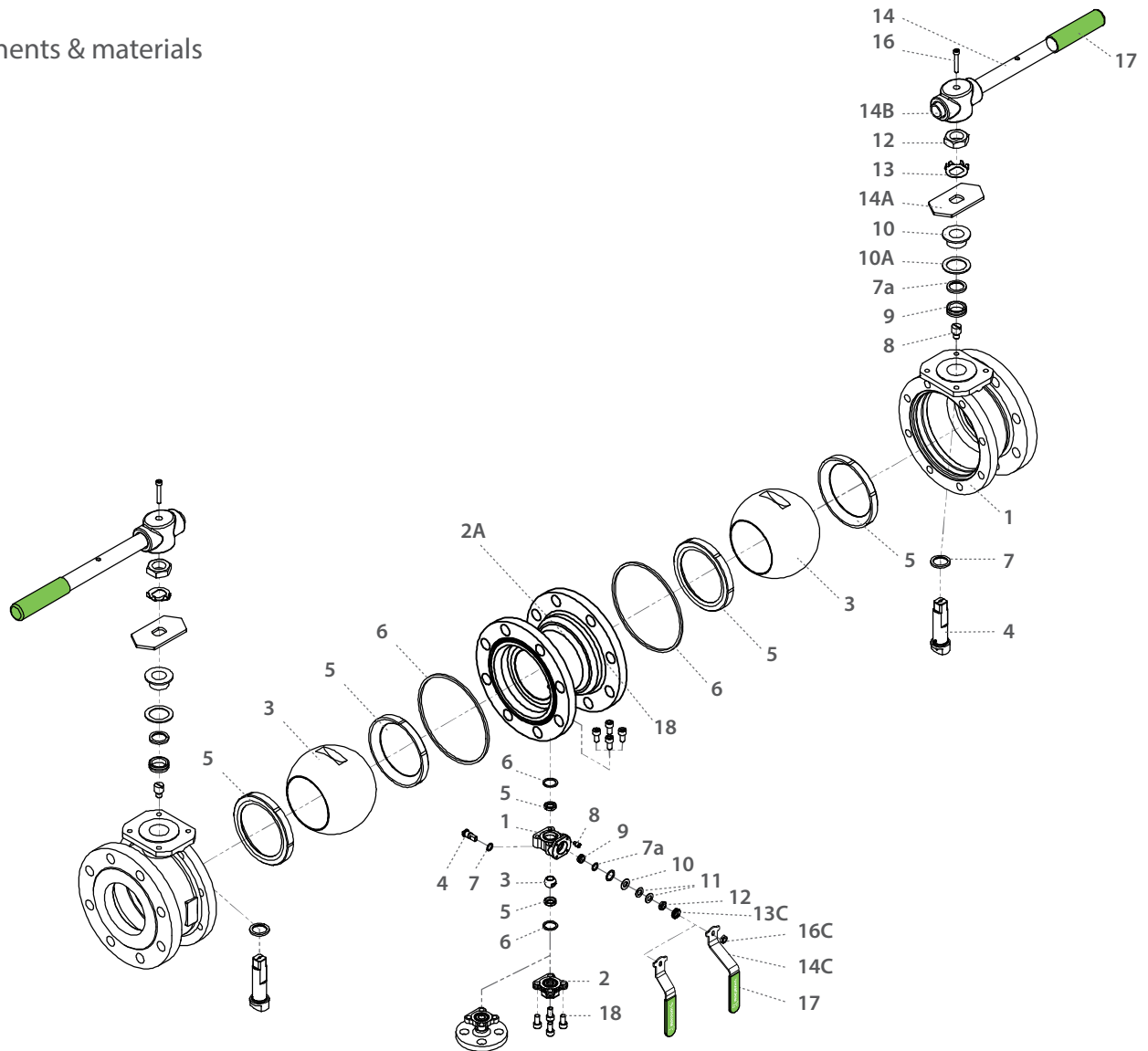

Item	Description	Material specifications	Qty.
1	Body	Acc. Ordering Code	3
2	Ends	Acc. Ordering Code	1
2A	Connection spool	S.St A479 316/316L, C.St A350 LF2	1
3	Ball	Acc. Ordering Code	3
4	Stem	Acc. Ordering Code	3
5*	Seat	Acc. Ordering Code	6
6*	Body seal	PTFE, RPTFE, TFM, UHMWPE, Graphite	4
7*	Stem thrust seal	PEEK, CF PEEK, PCTFE (KEL-F)	3
7a*	Anti-abrasion ring	PEEK, CF PEEK, PCTFE (KEL-F)	3
8	Stop pin	S. Steel	3
9*	Stem seal	CF PTFE, TFM, Graphite	3
10	Follower	S. Steel	3
10A*	Slide bearing	TF316	3
11	Disc spring	S. Steel	2

Item	Description	Material specifications	Qty.
12	Stem nut	S. Steel	3
13	Tab lock washer	S. Steel	2
13C	Locking clip	S. Steel	1
14	Handle	S. Steel	2
14C	Handle	S. Steel	1
14A	Stop plate	S. Steel	2
14B	Wrench head	S. Steel	2
16	Wrench bolt	S. Steel	2
16C	Handle nut	S. Steel	1
17	Sleeve	PVC	3
18	Body bolt	S. Steel	24-32
20	Anti-static spring	S. Steel	3
21	Anti-static plunger	S. Steel	3
23	Tag (not shown)	S. Steel	1