

# Installation, Operating & Maintenance

## Multiport Valves

### 62 & 61 Series



**Habonim USA**  
Toll Free Phone: 1-866-261-8400  
Toll Free Fax: 1-866-243-9959  
sales\_usa@habonim.com

**Habonim EUROPE**  
Tel: +34 640 384 759  
sales\_eu@habonim.com  
sales\_international@habonim.com

**Habonim AUSTRALIA**  
Tel: +61 400 001 988  
sales\_au@habonimau.com

**Habonim CHINA**  
Tel: + 86 21 64453190 \*146  
sales\_china@habonim.com

**Habonim ISRAEL**  
Tel: +972-4-6914911  
Fax: +972-4-6914935  
sales\_international@habonim.com

**Habonim UK**  
Tel: +44-1633-484554  
Fax: +44-1633-482252  
sales\_uk@habonim.com

**Habonim SINGAPORE**  
Tel: +65 6296 7828  
Fax: +65 6299 3184  
sales\_Singapore@habonim.com



## WARNINGS & SAFETY INSTRUCTIONS

Habonim cannot anticipate all of the situations user may encounter while installing and using Habonim valves. The user MUST know and follow all applicable industry specifications on the safe installation and use of these valves. Misapplication of the product may result in injuries or property damage. Refer to Habonim product catalogues, product brochures and installation, operating and maintenance manuals for additional product safety information or contact Habonim.

1. Keep hands and objects away from the valve ports at all times. Actuated valves could be accidentally operated, resulting in serious injury or valve damage.
2. Before removing a valve from the line, always make sure the line has been depressurized and drained. Cycle the valve a few times to relieve any pressure that could be trapped in the body cavity.
3. Utmost caution must be taken when handling a valve that has toxic, corrosive, flammable or a contaminant nature media flowing through its pipeline. The following safety precautions are recommended when dismantling valves with hazardous media:
  - 3.1. Wear safety glasses, protective headgear, clothing, gloves and footwear.
  - 3.2. Have available running water.
  - 3.3. Have a suitable fire extinguisher when media is flammable.
4. Do not try to operate a valve that exhibits any sign of leakage. Isolate the valve and either repair or replace it.
5. Do not use or substitute non Habonim components or parts in Habonim valves and assemblies.

## Contents

<b>1. General</b> .....	1
<b>2. Sil</b> .....	1
<b>3. Limitations</b> .....	2
<b>4. Storage</b> .....	2
4.1. Long Term Storage.....	2
<b>5. Installation</b> .....	3
5.1. General.....	3
5.2. Valve Marking and Labeling.....	4
5.3. Weld End Valves in-line - Extended Ends.....	5
5.4. Weld End Valves not in-line.....	6
5.5. Flanged Valves.....	6
5.6. Threaded End Valves.....	6
<b>6. Operating Instructions</b> .....	7
<b>7. Maintenance</b> .....	7
<b>8. Disassembly &amp; Assembly Manual</b> .....	8

## 1. General

This Installation, Operating & Maintenance manual represents the instructions required for safe use of Habonim ball valve. The manual relates to reduce and full bore valves.

Before using any of these series valves, read the entire IOM carefully and make sure everything is clear. Where in doubt, please consult with Habonim engineering team.

## 2. Sil

Under severe operating conditions inspection should be more frequently; detected defects should be repaired promptly. Severe operating conditions can be defined as:

- Application temperature less or above than specified on the valve tag label.
- Flow velocity higher than 5 m/sec for liquids, and 200 m/sec for gaseous
- Acidic media PH < 5 or alkaline media PH > 9

Habonim recommend a proof test interval of 12 months; in case of Fail to Open ESD system, a partial stroke is acceptable to confirm that the installation is functioning properly.

For ESD systems with a Fail-To-Close demand, it is necessary to plan a system shut-down; de-energize the system and inspect the valve turning to its fully closed position.

It is essential to log-in the following parameters on site QA records

as a proof for preserving SIL capabilities: date, hour, name and signature of the responsible engineer, air pressure on site, time to close the valve, time to open the valve.

Habonim recommend valve full maintenance operation every 500,000 cycles or 4 years, whichever comes first. The combined corrosion and erosion allowance for the valve body wall thickness is 1 mm. When this allowance has been eroded or corroded, mechanically removed or otherwise, the valve should no longer be used. Inspect the valve wall thickness every time the valve is maintained.

The estimated mean time to repair (MTTR) a valve, i.e. time net (line draining or cooling down time excluded from the valve MTTR) of replacing old valve with a new one is 60 minutes. Maintenance team must read and understand the Habonim product IOM before starting the operation. In case of a doubt please consult the Habonim engineering team.

When a valve has been repaired or any maintenance was performed, check the valve for proper function (proof testing). Any failures affecting functional safety should be reported to the Habonim factory.

Client should consult the Habonim factory in order to obtain the product assessment, FMEDA report, and other associated statistical data to satisfy SIL level.

### Special condition for safe use

1. When connected to an actuator the maximum rubbing speed of any component within the valve must not exceed 1ms<sup>-1</sup>.
2. The ambient temperature range for which these valves are suitable depends on the materials used in their construction and the pressure at which they will be used. The maximum withstand temperature is included in the Pressure Equipment Directive (PED) marking. The lower ambient will be specified in the documentation provided with each valve.

### 3. Limitations

The correct selection of materials of construction, seats and seals, internal valve components and pressure/temperature ratings determines the safe use of the valves and the particular performance requirements for the application. This information can be found on the name plate welded to the valve body. The combined corrosion and erosion allowance for the valve body wall thickness is 1(mm). When this allowance has gone, the valve should no longer be used. Inspect the valve wall thickness every time the valve is maintained. Refer to Habonim Corrosion Data Chart T-614 to determine the corrosion rate for your application.

As the variety of applications these valves can be used in is large, it is impossible to cover all installation and maintenance instructions for servicing the valves. It is the owner's responsibility to use the valves as recommended and in accordance with the pressure and temperature limits as stated in this manual. Where in doubt, please consult with Habonim.

Any unstable fluid or gas should be identified by its manufacturer and must not be used with Habonim valves.

**CAUTION:** The valves should be used in a well-designed, adequately protected system to ensure that external and internal pressure and temperature limits do not exceed the valve limits.

The valve rating is defined as the lower rating of the seat and valve body.

Valve surface temperature may become extremely hot or cold due to operating conditions. Prevent any type of direct contact with the valve that may cause harm or injury. Avoid direct contact with the valve by wearing protective gloves.

The valves should be used in a well-designed, adequately supported piping system such that it will not be subjected to undue forces, stresses or shock loads during service.

The valves are not designed to operate during or after earthquakes or under fatigue conditions. It is the responsibility of the owner to determine if fatigue conditions exist.

Do not allow dust layers to build up on the equipment.

The process fluid temperature shall not exceed the ignition temperature of the dust.

### 4. Storage

Prior to storage, inspect the valve for shipping damage. Keep all protective packaging, flange covers and end caps attached to the valves during storage. It is recommended to keep the valves in a clean and dry environment until it is ready for use.

Carbon Steel valves have a "black oxide" and oil dipped finish. This nontoxic process is performed to retard rusting during storage. It is not a substitute for paint or other means of protective coating to be applied to the valve once installed.

Stainless steel valves have their natural finish and do not need any additional protection once installed.

#### 4.1. Long Term Storage

4.1.1. It is advisable to store the valves in waterproof conditions. Ball valves should be protected to safeguard against humidity, Moisture, dust, dirt, sand, mud, salt spray, and sea water.

4.1.2. Manual ball valves must remain in the open position during the period of storage.

4.1.3. Actuated valves (fail to close position) remain in closed position during this time.

4.1.4. Valves may be stored as shipped, provided the above storage location and equipment orientation instructions are followed

4.1.5. In order to prevent damage, protective covers on valve ends should not be removed until immediately prior to installation.

4.1.6. Visual inspection should be performed on a semi-annual basis and results recorded.

## 5. Installation

The installation procedure for Habonim ball valves is critical to ensuring both long life and satisfying performance. Valves stored on site, awaiting installation, should be kept in their original packing, in dry conditions, where damage will not occur (See Para. 4).

Before carrying out the installation, it is important to follow the basic procedures described below:

### 5.1. General

- 5.1.1. It is essential to flush the line prior to assembling any valve on the line.
- 5.1.2. Carefully unpack the valve and check valve nameplate for identification of materials.
- 5.1.3. Remove any special packing materials surrounding the valve.
- 5.1.4. Check the valve for the flow direction indication marks. Appropriate care must be taken, to install the valve for proper flow orientation.
- 5.1.5. Inspect the valve interior through the end ports to determine it is clean and free from foreign matter according to ASME G93-03E1.
- 5.1.6. Cycle the valve and inspect any functionally significant features.
- 5.1.7. Read all the literature and note any special warning tags or plates attached to the valve.
- 5.1.8. Before installation check to insure that the flow line balls are in the fully open position in order to prevent possible damage to the balls and seats. The valve performance depends on its original conditions. At any stage do not leave the valve in the partially open position on either of the lines.

**5.2. Valve Marking and Labeling**

- 5.2.1. All valves marking is on a nameplate which is spot welded to the valve body.
- 5.2.2. Valves for the European market and above 1" carry the CE mark with the information required by the PED.
- 5.2.3. The valve markings that are according to API-6D standard are presented in order to provide the user full traceability and information regarding the valve. Unless otherwise requested, nameplates will be secured to the valve body and will be visible to user. The information on the nameplate is as described below:

**Standard Habonim Tag**

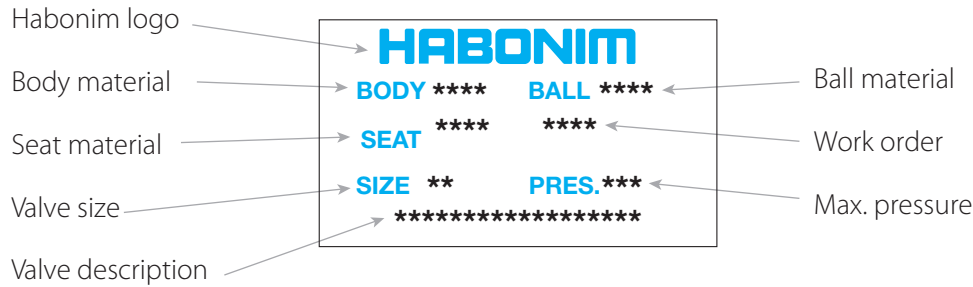

**Standard CE Tag**

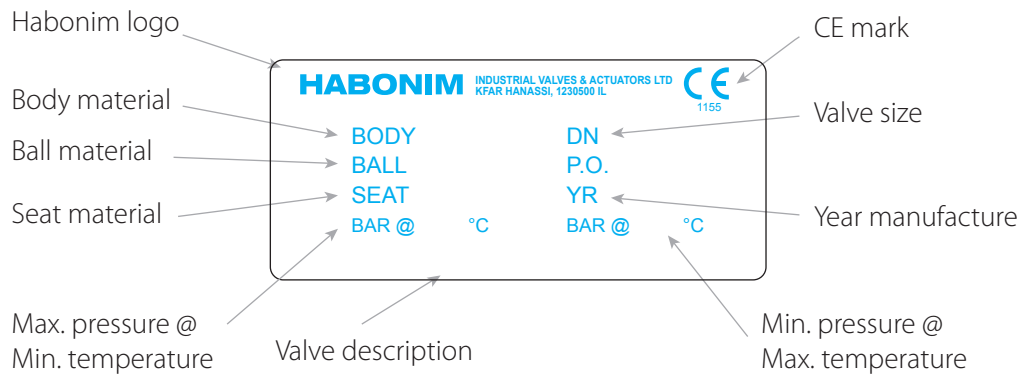

**Standard ATEX Tag**

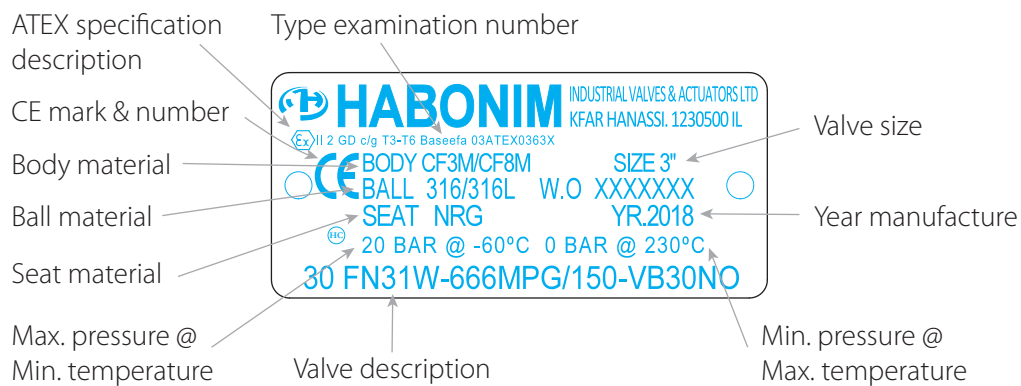

**Habonim API-6D Tag**

<span style="float: right;">6D-1278</span>			
Valve Description			
Pressure Rating	Class	PN	
Pressure / Temperature	bar @ °C	bar @ °C	
Limits	psi F	psi F	
Size	DN	NPS	F.T.F.
Materials of Construction	Body / Ends	Stem	Ball / Seat
	Seat feature	Insert	Seal
S/N	Valve Serial Number		
QSL-LEVEL	QSL-1		
API#	API License No.		
Design	Date	Manufacturing Date MM/YY	
Design Standard	API 6D / B16.34 NCA		
Notified body symbols	[ ]		

**5.3. Weld End Valves in-line - Extended Ends**

- 5.3.1. Welding of valves shall be performed by a qualified person according to the ASME Boiler Construction Code Section IX. For valves to be welded within the EEA, refer to the requirements of ESR 3.1.2 of the Pressure Equipment Directive 97/23/EC.
- 5.3.2. Valves with Delrin® seats must be disassembled before welding in line. For more information on recommended welding procedures or seat materials, please consult with Habonim.
- 5.3.3. Valves that will be welded directly to the line must be in the fully open position to protect the ball and seats from excessive temperatures during the welding procedures.
- 5.3.4. It is recommended to remove the valve wrench during the welding procedure. Protect or remove actuators from weld splatter or arc strikes. Valves in the "Fail Close" position should be cycled to the open position.
- 5.3.5. Use a temperature stick and a wet cloth wrapped around the center section to prevent overheating.

**WARNING: DO NOT heat the center section over 150°C (300°F).**

- 5.3.6. Align valve to pipe line, ensuring proper fit to minimize pipe load. Tack weld only.
- 5.3.7. Complete welding in small segments. Allow enough time for cooling between each segment.
- 5.3.8. After completing the welds, wait for the valve to cool below 90°C (200°F).
- 5.3.9. Replace the wrench or actuator. It is recommended not to rotate the valve to the closed position before flushing the line.

#### 5.4. Weld End Valves not in-line

- 5.4.1. Welding of valves shall be performed by a qualified person according to the ASME Boiler Construction Code Section IX. For valves to be welded within the EEA, refer to the requirements of ESR 3.1.2 of the Pressure Equipment Directive 97/23/EC.
- 5.4.2. Valves that will be disassembled before welding carry a packet with replacement body seals. Follow the **DISASSEMBLY** section but do not discard of the seat rings.
- 5.4.3. Prior to welding the ends to the pipe, make sure their flats are aligned to the body flats.
- 5.4.4. Do not scratch or cut the seats and sealing surfaces of the valves as this will cause valve leakage.
- 5.4.5. Assemble the valve without the ball and seats and follow the **ASSEMBLY** chapter.
- 5.4.6. After the valve cools down, follow again the **DISASSEMBLY** section and the **ASSEMBLY** section.

#### 5.5. Flanged Valves

- 5.5.1. Before installing the valves, make sure the flanges and the pipe are free from grit, dirt or burrs.
- 5.5.2. The flanges must be aligned and parallel with the correct distance to allow the valve face-to-face dimension and gaskets to fit between.
- 5.5.3. Insert the valve between the flanges. If tilting or levering of the flanges is required, avoid harming the sealing surfaces of the flanges.
- 5.5.4. Align the valve and the pipe counter flanges and insert at least 2 bolts at the lowest side of the flange to support the gaskets.
- 5.5.5. Slide the gaskets between the flanges. Insert the remaining bolts and thread the nuts hand tight.
- 5.5.6. Before tightening the bolts, make sure the gaskets are aligned with the raised face of the flanges.
- 5.5.7. Tighten the flange bolts, with a torque values determined by the gasket manufacturer, other variables like gasket type and material, bolt, flange and lubricant affect the tightening torque values.

**IMPORTANT: the tightening torque selected must be high enough to ensure adequate strain (stretch) in the bolt, but not so high as to cause the material to be taken beyond yield into the plastic response region. If the initial bolt stress is too low the total amount of strain (stretch in the bolt) is low and under these circumstances any subsequent reduction in thickness of the gasket due to creep will quickly result in loss of bolt strain and subsequent leakage.**

- 5.5.8. It is recommended to use ring spanners to tighten and support the bolts and nuts.
- 5.5.9. **Note:** bolts tightening must be uniform in order to create a parallel movement of the two flanges and uniform deformation of the gasket in between them.
- 5.5.10. Before flushing the line, be sure the valves are in the fully open position. Fail-to-close actuated valves should be operated to the open position for flushing.
- 5.5.11. Before pressure testing the valves, bring the valves to the half open position to ensure pressure reaches the stem seals and to avoid unnecessary loading of the seats. Fail-to-close actuated valves should be brought to the half-open position.

#### 5.6. Threaded End Valves

- 5.6.1. Valves with threaded ends should be treated as a single unit and should not be dismantled when installing to pipeline.
- 5.6.2. Before installing the valves, make sure that the threads on the mating pipe are free from excessive grit, dirt or burrs.
- 5.6.3. When tightening the valve, apply a pipe wrench or spanner to the end connector closest to the pipe being worked, using standard piping practices.
- 5.6.4. Use appropriate joining sealants material in correct quantities.
- 5.6.5. If "back-welding" is required on threaded end valves, refer to the instructions for Weld End valves or to the "Habonim Welding Instructions" bulletin.



## 6. Operating Instructions

Habonim Valves provide tight shut off when used under normal conditions and in accordance with Habonim's published pressure/temperature chart.

If these valves are used in a partially open (throttled) position, seat life may be reduced. Consult with Habonim for the proper seat material selection.

On manual operated valves, the valve operation is done by turning the valve handle 90° clockwise to open (handle is parallel to flow line), and 90° counter clockwise to close (handle is perpendicular to flow line).

For unidirectional designed valves; a flow arrow indicates the flow direction of the valve for proper installation. A silicone-based lubricant is applied to assist valve break in. The lubricant, if unacceptable, may be removed by a solvent wash.

If a shut-off valve is installed for end of line service, it must be ensured that it is closed with a blind end connection and the valve is secured against being opened unintentionally.

**WARNING: Never look into the valve bore while the valve is in a flow line. Pressure and fluids could escape from the valve causing harm or injury.**

**To prevent leakage, malfunctions resulting from internal wear or seal degradation, the user must establish a preventive maintenance and inspection program. This program must include:**

- 1. Inspection of parts to detect loss of wall thickness which may result in decreased pressure capacity (see Para. 3 for acceptable reduction of wall thickness).**
- 2. Routine replacement of seals and inspection for proper operation (See Para. 7 for maintenance instructions).**

**Valve operating torques, as published in the Habonim literature, are the normal expected maximum break-out torques. These torques have been confirmed by laboratory testing of each valve under controlled conditions. Highly viscous or abrasive media, frequency of operation and temperature fluctuations could cause an increase in valve torque.**

## 7. Maintenance

HABONIM valves have a long and reliable life, and maintenance is seldom required. When maintenance is necessary, valves can be refurbished on site.

To extend valve performance and reduce possible plant problems, the following procedures should be followed:

- 7.1. If leakage around the stem is noticed, check the stem nut torque according to value in Table 1 in the disassembly and assembly manual. If the leak continues, tighten the gland nut about a 1/6-turn as a routine maintenance procedure. This will compensate for any wear or settling of the gland packing.

**Caution: Excessive tightening of the stem nut can result in accelerated seal wear and high valve operating torque.**

- 7.2. If the valve is removed from the line and disassembled, replacement of all seats and seals is recommended using the appropriate Habonim Repair kit. Examine all metallic sealing surfaces such as ball, stem, and the surfaces on the end connectors that contact the seats for wear, corrosion or damage.
- 7.3. Only Habonim authorized spare parts should be used. Default repair kit parts from Habonim can be found at "components & materials" in Habonim catalog.
- 7.4. In addition to repair kits, other spare parts are available from Habonim, such as stem, glands, bolts, screws and nuts.
- 7.5. Should additional parts be required, it is recommended that the complete valve be replaced.
- 7.6. When ordering repair kits, please provide the valve size and full figure number code and series, engraved on the valve ID tag.

# Disassembly & Assembly Manual

## Multiport Valves

Series included:

**61 & 62 Series**

Sizes included:

**3/4" (1/2"FB) - 4" (DN20 - DN100)**

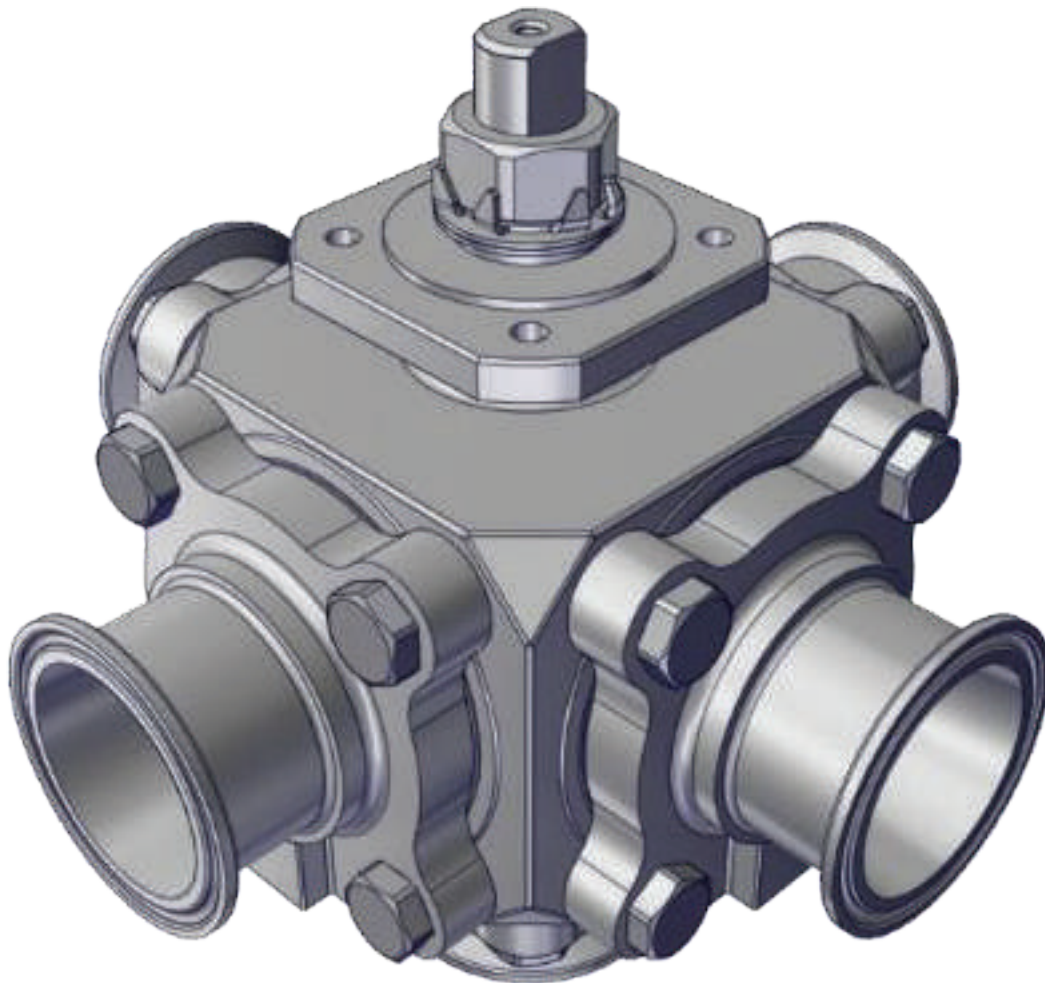

## **WARNINGS & SAFETY INSTRUCTIONS**

Habonim cannot anticipate all of the situations user may encounter while installing and using Habonim valves. The user **MUST** know and follow all applicable industry specifications on the safe installation and use of these valves. Misapplication of the product may result in injuries or property damage. Refer to Habonim product catalogues, product brochures and installation, operating and maintenance manuals for additional product safety information or contact Habonim.

1. Keep hands and objects away from the valve ports at all times. Actuated valves could be accidentally operated, resulting in serious injury or valve damage.
2. Before removing a valve from the line, always make sure the line has been depressurized and drained. Cycle the valve a few times to relieve any pressure that could be trapped in the body cavity.
3. Utmost caution must be taken when handling a valve that has toxic, corrosive, flammable or a contaminant nature media flowing through its pipeline. The following safety precautions are recommended when dismantling valves with hazardous media:
  - 3.1. Wear safety glasses, protective headgear, clothing, gloves and footwear.
  - 3.2. Have available running water.
  - 3.3. Have a suitable fire extinguisher when media is flammable.
4. Do not try to operate a valve that exhibits any sign of leakage. Isolate the valve and either repair or replace it.
5. Do not use or substitute non Habonim components or parts in Habonim valves and assemblies.

## **Contents**

<b>1. General</b> .....	<b>10</b>
<b>2. Disassembly</b> .....	<b>10</b>
<b>3. Assembly</b> .....	<b>11</b>
<b>4. Disassembly and assembly of handles</b> .....	<b>16</b>

## 1. General

- It is strongly recommended to review both the disassembly and assembly chapters before getting started
- Both the disassembly and assembly chapters are for bare stem valves
- For any discrepancies please contact Habonim

## 2. Disassembly

- 2.1. Cycle the valve with the line pressure fully relieved before attempting to remove the valve from the pipeline, to insure pressure has also been discharged from the valve cavity.
- 2.2. Remove all body bolts.
- 2.3. Bring out the body center section.
- 2.4. Remove and discard the seats, support seats, body seal, and seal seats.

**WARNING: Be careful not to damage the sealing surfaces.**

- 2.5. Support the ball to prevent it from falling out of body and set the ball aside in a clean secure area for reuse.
- 2.6. Remove anti-abrasion ring, follower, two disc springs, tab lock washer and the stem nut. Place all components removed, in a clean secure area.
- 2.7. Push the stem down into the body and remove it.
- 2.8. Discard the stem thrust seals, care taken not to scratch or nick the stem bore area of the body. Clean the stem and stem bore area.

### 3. Assembly

The following instructions are for off-line assembly of valves all sizes.

- 3.1. Lubricate the stem thrust seal and the stem seal with appropriate lubricant.
- 3.2. Place the stem thrust seal on the stem.
- 3.3. Insert the stem horizontally into the center body with the threaded side first and carefully guide it up through the stem bore

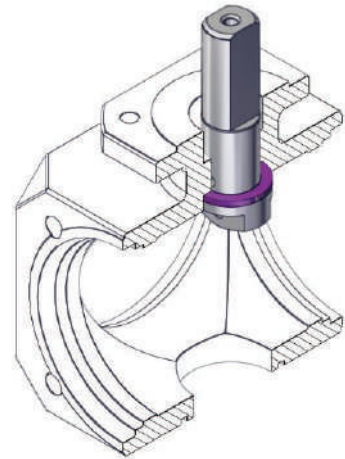
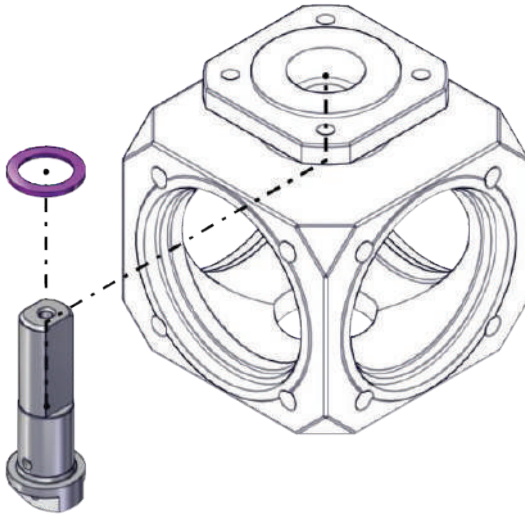

**WARNING: For valves size 3" and above verify that the thrust seal chamfer faces down.**

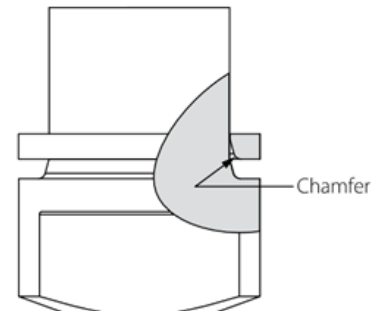

**½"-1½" (DN15-DN40) Stem Assembly**

3.4. Holding the stem up insert the stem seal over the stem and into the stem bore. Place the anti-abrasion ring, follower, two disc springs and Thread the stem nut onto the stem.

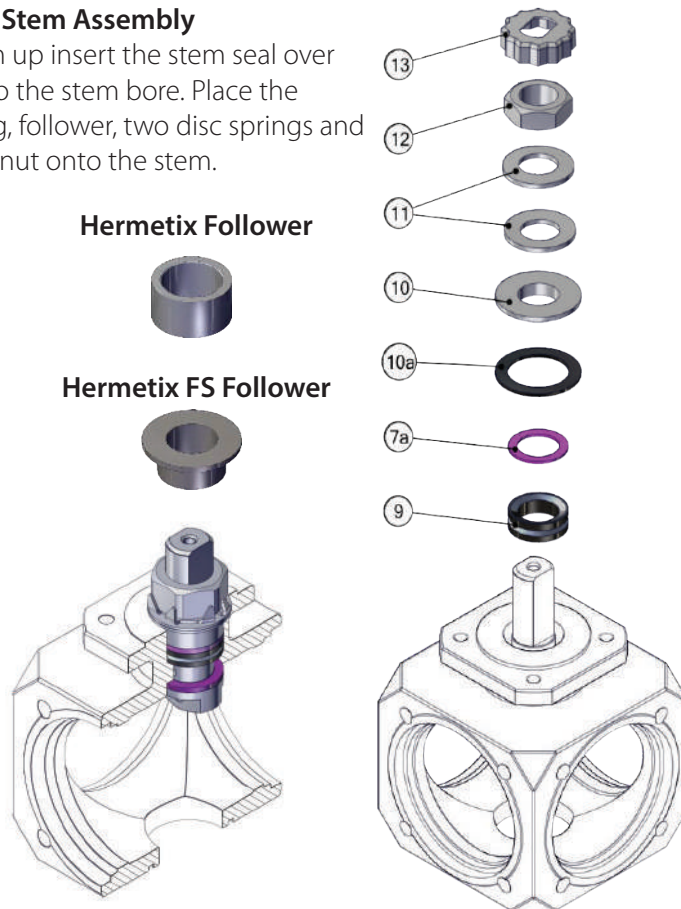

Description	BOM ID
Anti -abrasion ring	7a
Stem Seal	9
Follower*	10
Slide bearing**	10a
Disc spring	11
Location ring	11a
Stem nut	12
Locking Clip	13

**2" - 4" (DN50-DN100) Stem Assembly**

3.5. Holding the stem up insert the stem seal over the stem and into the stem bore. Place the anti-abrasion ring, follower, two disc springs, tab lock washer and Thread the stem nut onto the stem.

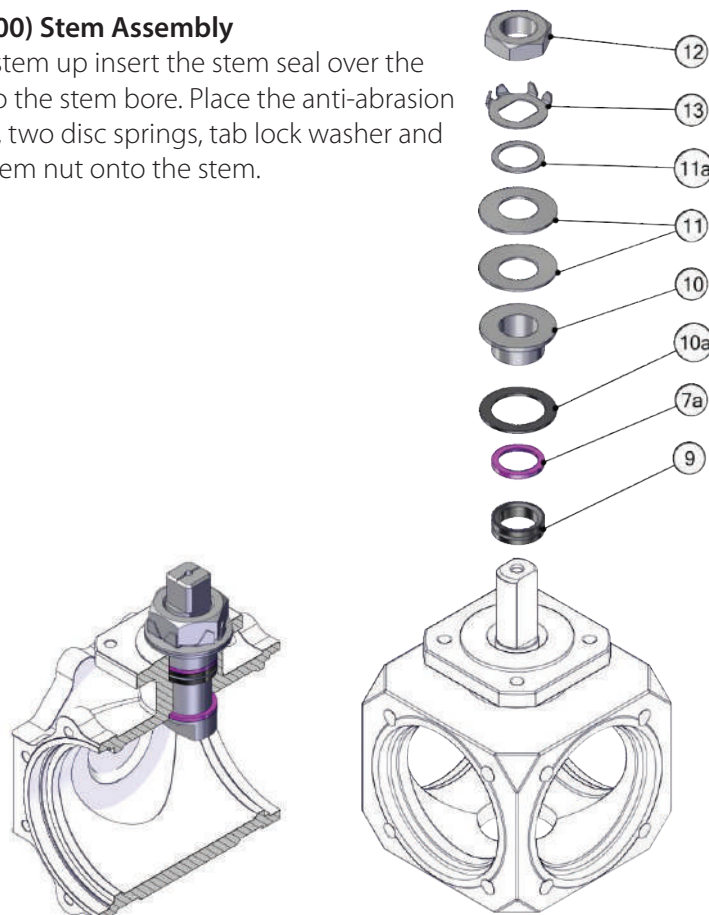

Description	BOM ID
Anti -abrasion ring	7a
Stem Seal	9
Follower*	10
Slide bearing**	10a
Disc spring	11
Location ring	11a
Stem nut	12
Tab lock washer	13

\* The follower of Hermetix and Hermetix fire safe are different

\*\* Only for Hermetix fire safe valves

3.6. Tighten the stem nut onto the stem according to **table 1** and lock the locking clip.

**Table 1:**

Valve Size	Stem Size	Stem Thread	CF PTFE		HERMETIX		GRAPHITE	
			N-m	Lb-In	N-m	Lb-In	N-m	Lb-In
1"-1¼"	1"	7/16" - 20 UNF	9	80	11	97	11	97
1½"	1½"	9/16" - 18 UNF	13	115	15	133	16	140
2"-2½"	2-½"	M20x2.5 - 6G	30	265	30	265	30	265
3"-4"	3"	1" - 14 UNS	60	530	60	530	72	637

**Important: An excessively tightened stem nut can cause excessive packing wear and increase stem torque.**

3.7. Into the metallic support seats place the soft seats, body seal, and seal seats. Place all the assembled components, in a clean secure area

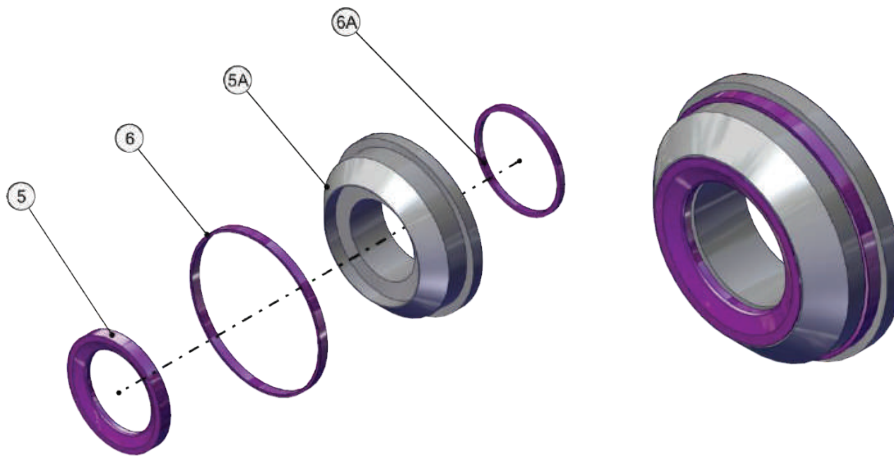

**61 Series ball assembly**

3.8. Place the seat into the back seat support and insert it to the valve body.

3.9. Place the ball in the center body according to the flow pattern until the stem tongue is engaged and secure the ball to prevent it from falling out.

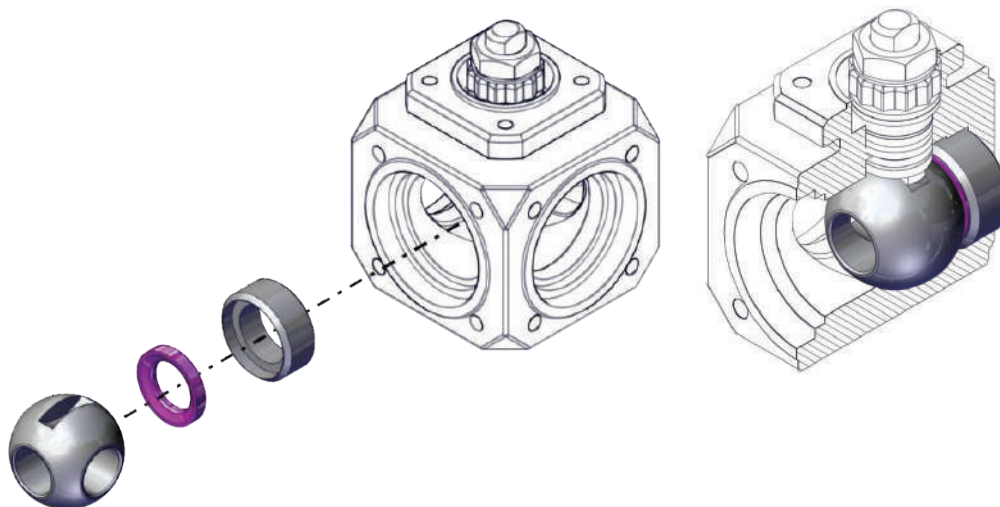

**62 Series ball assembly**

3.10. Place the ball in the center body according to the flow pattern until the stem tongue is engaged and secure the ball to prevent it from falling out.

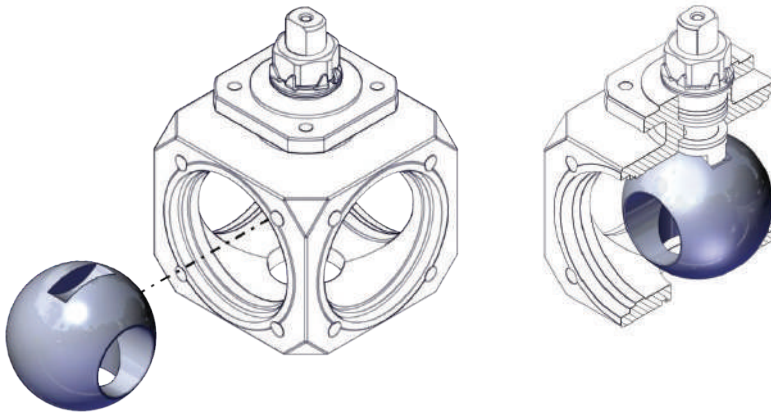

3.11. Place the assembled seats into the body.

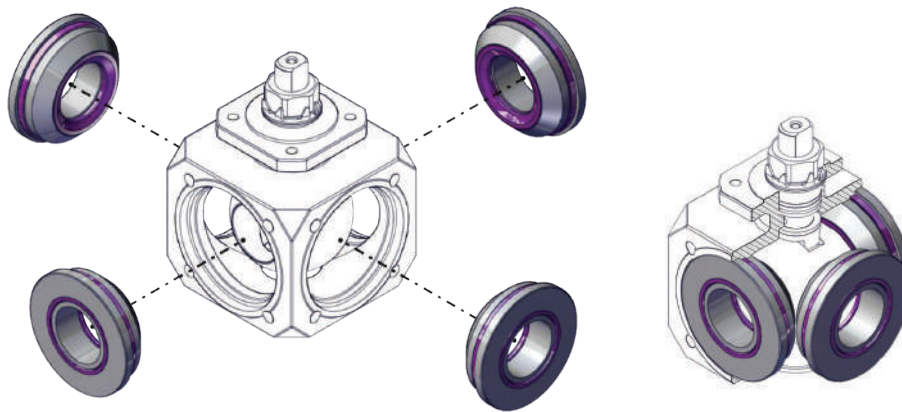

3.12. To prevent galling of threads of bolts or nuts, lubricate threads with an anti-galling compound.

3.13. Ease back the body assembly between end connectors, taking care not to score faces or damage seals, and reinstall body bolts

3.14. Insert the bottom end seal into the valve body.

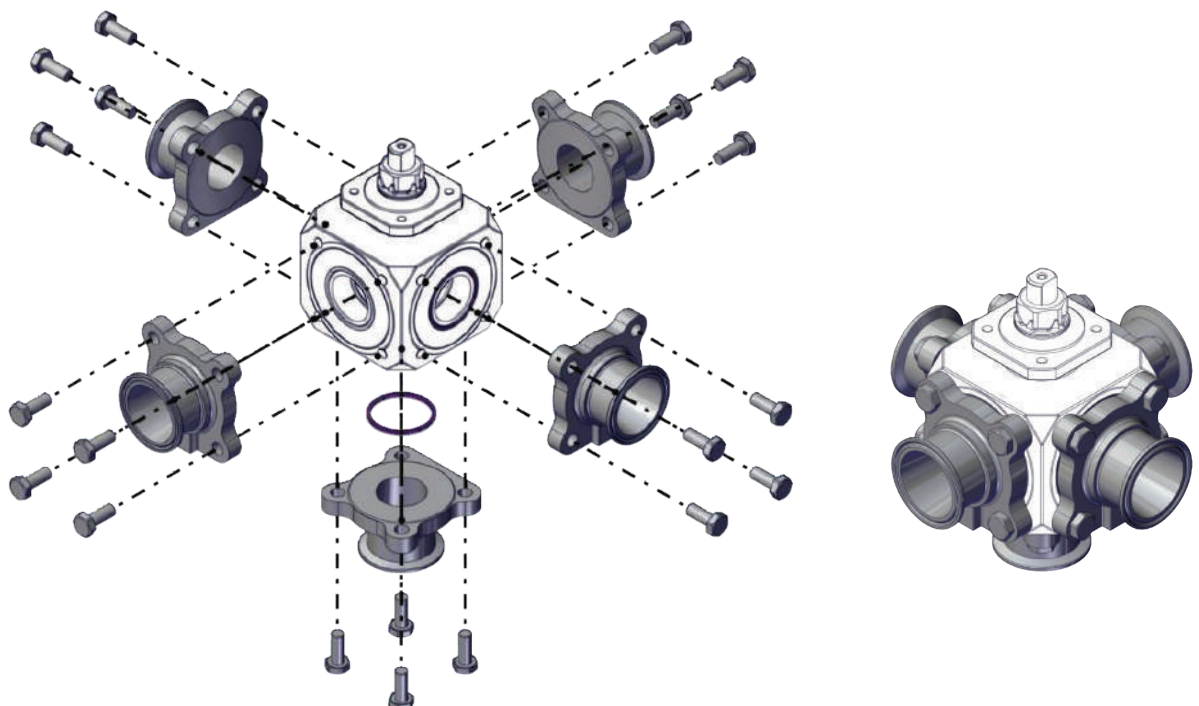



3.15. Apply initial tightening of the body bolts according to tightening sequence as illustrated:

**Tighten pattern:**

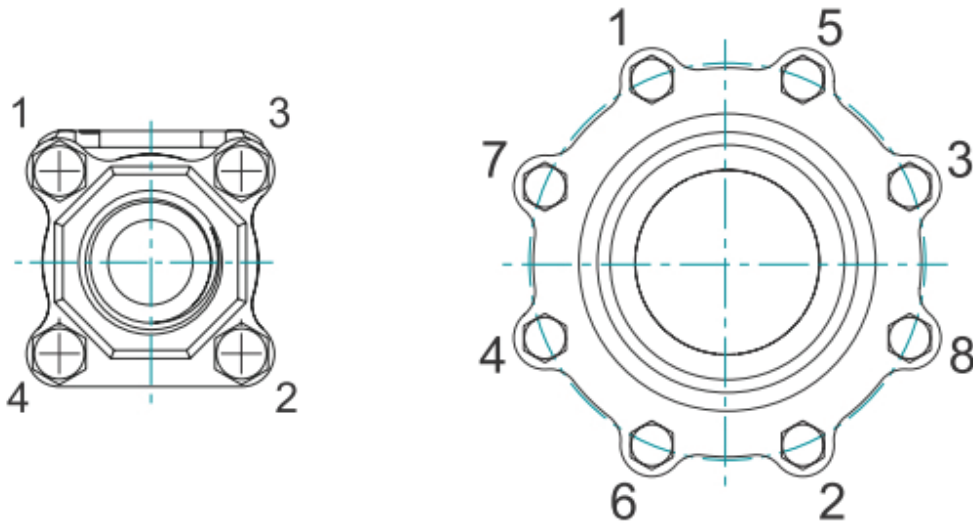

3.16. Tighten the body bolts according to **table 2**:

**Table 2:**

Bolt material	Thread	Valve size	Required torque	
			N-m	Lb-In
Stainless Steel: Grade A2-70 Grade A4-80	M6	½"-¾"	10	90
	M8	1"-¼"	20	180
	M10	1½"-3"	40	350
	M12	4"	65	575

#### 4. Disassembly and assembly of handles

The following instructions are for all Habonim Hermetix and Hermetix fire safe standard "SHARK" handles and handles for larger valves (sizes 2-1/2" and above).

##### 4.1. The following instructions are for "SHARK" handle design disassembly

4.1.1. Remove the handle nut, serrated washer, handle, locking clip, stem nut, two disc springs, follower, anti-abrasion ring and stem seal. Place all components removed, in a clean secure area.

##### 4.2. The following instructions are for "SHARK" handle design assembly

- 4.2.1. Holding the stem up insert the stem seal, anti-abrasion ring, follower, slide bearing, two disc springs and Thread the stem nut onto the stem.
- 4.2.2. Tighten the stem nut onto the stem according to **table 1**.
- 4.2.3. Insert the locking clip, handle, serrated washer and the stem bolt.

Description	BOM ID
Anti -abrasion ring	7a
Stem Seal	9
Follower*	10
Slide bearing**	10a
Disc spring	11
Stem nut	12
Locking Clip	13
Handle	14
Serrated Washer**	15
Handle nut	16

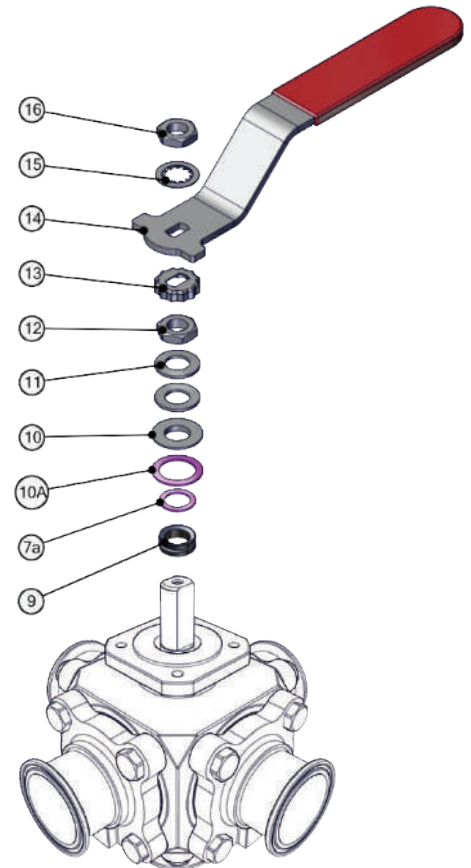

##### 4.3. The following instructions are for handle disassembly of larger valves (sizes 2" and above)

4.3.1. Remove wrench bolt, handle, stem nut, tab lock washer, Stop plate, follower, slide bearing, anti-abrasion ring and stem seal. Place all components removed, in a clean secure area.

##### 4.4. The following instructions are for handle assembly of larger valves (sizes 2" and above)

- 4.4.1. Holding the stem up insert the new stem seal over the stem and into the stem bore. Place the anti-abrasion ring, slide bearing, follower, Stop plate and the tab lock washer.
- 4.4.2. Thread the stem nut onto the stem and tighten the stem nut according to table 1 and lock the locking clip onto the nut.
- 4.4.3. Place the wrench head on the stem making sure it is parallel to the stem groove for ball valve position. Insert the handle through the wrench head and tighten with the wrench bolt.

Description	BOM ID
Anti -abrasion ring	7a
Stem Seal	9
Follower*	10
Slide bearing**	10a
Stem nut	12
Tab lock washer	13
Handle	14
Stop plate	14A
Wrench head	14B
Wrench bolt	16

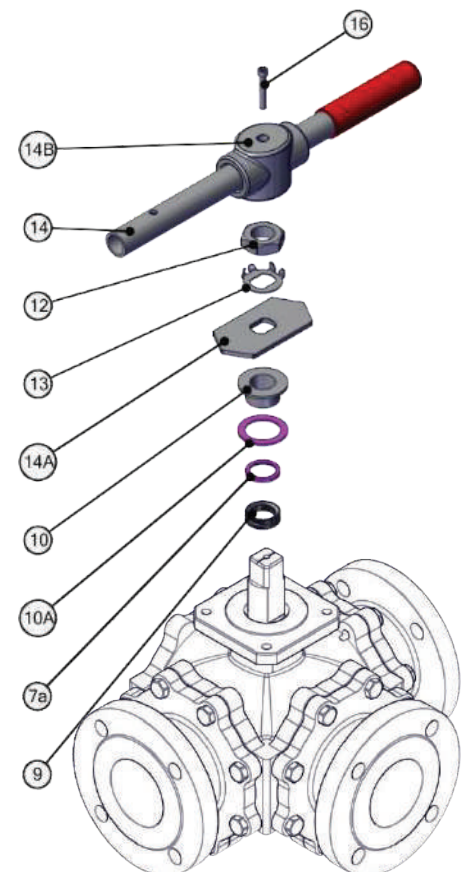

\* The follower of Hermetix and Hermetix fire safe are different.

\*\* Only for Hermetix fire safe valves