

METRIC

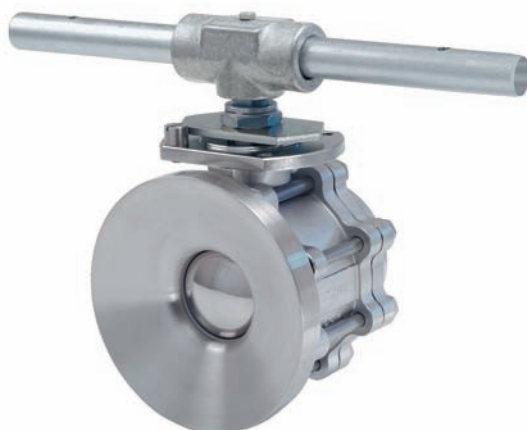

FLUSH TANK BALL VALVES

R47P&R48 SERIES



DEDICATED TO INNOVATION

FLUSH TANK BALL VALVES

The **HABONIM "R" Series Flush Tank** incorporates all the advantages of **47P & 48 series 3- piece ball valve** (see bulletins P111 & P140). The innovation of the "R" series valve is the geometric design of the pad, which is an integral welded part of the tank surface, allowing a smooth flow and preventing stagnation of the media. The result is a perfect adaptor between reactor and valve body. The pad is easy to install (refer to welding instructions page 4) designed to minimize the diameter of the prepared tank bore, reducing installation time, welding operations, and most important, minimizing the stress concentration and tank twisting caused by weld over-heating.

HABONIM standard R47P & R48 flush tank valve offers the best solution:

- Where minimum "dead space" between ball and tank is required.
- Where media could stagnate at tank outlet.
- Where full blending of reactor volume is imperative.

Flush Tank ball valve advantages over conventional Flush Tank valve

- Higher Cv
- Direct flow
- Simple quarter-turn operation
- Less expensive
- Low weight
- Easy maintenance

"R" series - Special features

CIP/SIP

Clean In Place /Steam In Place - design used in applications where media can become trapped in the cavity between ball sphere and the i.d. of the body, or where it may be necessary to sanitize the valve and/or pipe lines with steam or cleaning agent.

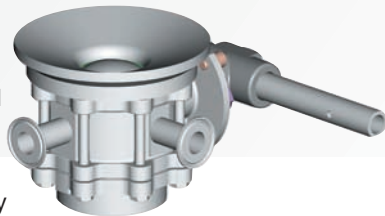

Flush Tank Control valve

Incorporate control systems (see bulletin P-411) and flush bottom tank valves, especially applicable in weight control systems when accuracy of batch is crucial. The V notch ball is designed according to the process parameters, providing constant flow of media while the differential height (upstream pressure) in the tank varies from maximum to zero.



Flush Tank Steam jacket valve

Used in service applications such as chocolate, wax, syrup etc. where reduction of media viscosity is crucial to maintain the flow through the valve. Stainless steel jacket welded directly to the valve body creates an external chamber, maintains maximum pressure of 150 psi of saturated steam, thermal oil etc. To define the required steam jacket you must specify the type, size and number of ports (inlet and outlet).

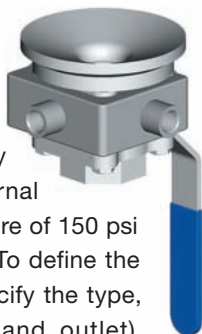

Actuation

HABONIM offers a selection of pneumatic, four piston, Compact actuators (see bulletin B-360) mounted horizontally to the flush tank valve ISO top pad. Due to flat bottom tanks design or thermal jacketed tanks, direct mounting installation is difficult. Therefore Habonim offers special design of extended mounting brackets.

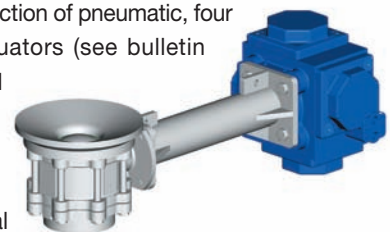

T- Ball

The special ball design ensures that the upstream side is fully shut off, whilst the downstream side is exposed to the valve cavity and the downstream pipeline. Normally used where media could stagnate at valve cavity or in applications where frequent changes are required without mixing.



Flush Pipe valves

Special flush pipe end with the same geometry of the pipe line (i.e. diameter and wall thickness) designed to provide minimum "dead volume" in pipe lines, preventing media from stagnating and fully insuring drainage of pipe cavities.

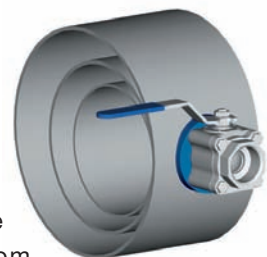

Three basic options are available with the Habonim "R" series:

- R47P Series standard port
- RB47P Series full port
- R48 Series tube bore - for highly pure applications

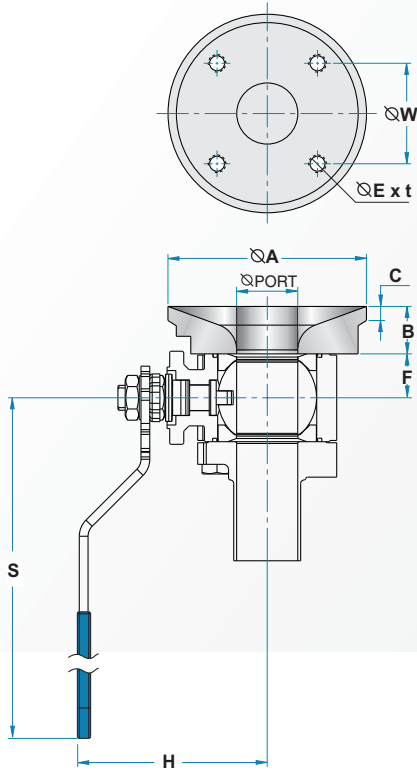

R47P & RB47P SERIES

Reduced port	Full port	Unit	\varnothing Port	Valve Dimensions							Ext (depth)
				A	B	C	W	F	H	S	
1/2"	1/4"	mm	11.1	60.0	21.0	6.0	31.8	10.3	61.5	160	M6x(8mm)
	3/8"	inch	0.44	2.36	0.83	0.24	1.25	0.41	2.42	5.91	
3/4"	1/2"	mm	14.3	80.0	20.6	6.0	38.1	12.26	63.9	150	M6x(8mm)
		inch	0.56	3.15	0.81	0.24	1.5	0.48	2.52	5.91	
1"	3/4"	mm	19.05	95.5	21.5	8.0	44.5	15.85	79.4	187.0	M8x(9mm)
		inch	0.75	3.76	0.85	0.31	1.75	0.62	3.13	7.36	
1 1/4"	1"	mm	25.4	108.0	24.0	8.0	50.8	20.45	84.1	187.0	M8x(9mm)
		inch	1.00	4.25	0.94	0.31	2.00	0.81	3.31	7.36	
1 1/2"	1 1/4"	mm	31.8	113.0	27.0	8.0	57.2	24.2	97.0	237.0	M10x(12mm)
		inch	1.25	4.45	1.06	0.31	2.25	0.95	3.82	9.93	
2"	1 1/2"	mm	38.1	138.0	29.0	10.0	66.7	28.15	101.8	237.0	M10x(12mm)
		inch	1.50	5.43	1.14	0.39	2.63	1.11	4.01	9.33	
2 1/2"	2"	mm	50.8	164.0	30.0	10.0	84.0	36.3	115.1	237.0	M10x(12mm)
		inch	2.00	6.46	1.18	0.39	3.31	1.43	4.53	9.33	

R48 SERIES TUBORE

Valve Size	Unit	\varnothing Port	Valve Dimensions							Ext (depth)
			A	B	C	W	F	H	S	
1/2"	mm	9.40	21.0	21.0	6.0	31.8	10.3	61.5	150.0	M6x(8mm)
	inch	0.37	0.38	0.83	0.24	1.26	0.41	2.42	5.91	
3/4"	mm	15.75	20.6	20.6	6.0	38.1	12.25	67.9	150.0	M6x(8mm)
	inch	0.62	0.81	0.81	0.24	1.50	0.48	2.67	5.91	
1"	mm	22.1	21.5	21.5	8.0	44.5	17.75	84.8	187.0	M8x(9mm)
	inch	0.87	0.85	0.85	0.31	1.75	0.70	3.34	7.36	
1 1/2"	mm	34.8	27.0	24.0	8.0	57.2	25.0	107.1	236	M10x(12mm)
	inch	1.37	1.06	0.94	0.31	2.25	0.98	4.22	9.29	
2"	mm	47.5	30.0	27.0	10.0	84.0	36.35	143.1	256	M10x(12mm)
	inch	1.87	1.18	1.06	0.39	3.31	1.43	5.63	10.08	

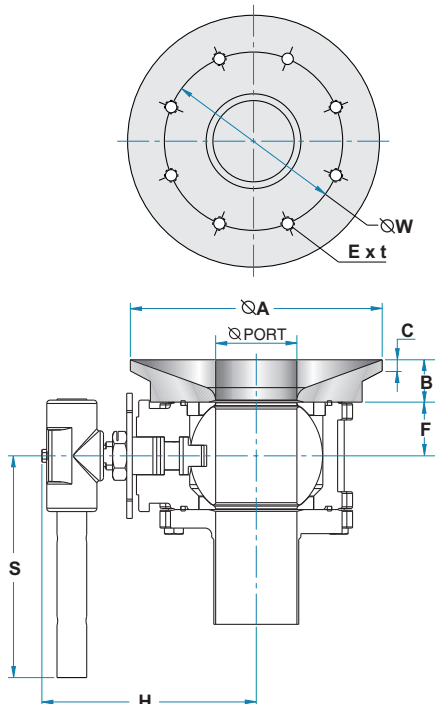

R47P & RB47P SERIES

Reduced port	Full port	Unit	\varnothing Port	Valve Dimensions							Ext (depth)
				A	B	C	W	F	H	S	
3"	2 1/2"	mm	63.6	188.0	34.0	10.0	139.7	41.65	185.0	400.0	M10x(12mm)
		inch	2.50	7.40	1.34	0.39	5.50	1.64	7.28	15.75	
4"	3"	mm	82.7	226.0	38.0	10.0	177.0	54.4	200.0	600.0	M12x(18mm)
		inch	3.26	8.90	1.50	0.39	6.97	2.14	7.87	23.26	
-	4"	mm	100.0	252.0	45.0	12.0	200.0	61.5	211.0	600.0	M16x(18mm)
		inch	3.94	9.92	1.77	0.47	7.87	2.42	8.31	23.62	

R48 SERIES TUBORE

Valve Size	Unit	\varnothing Port	Valve Dimensions							Ext (depth)
			A	B	C	W	F	H	S	
2 1/2"	mm	60.2	188.0	34.0	10.0	139.7	41.68	185.1	401.0	M10x(12mm)
	inch	2.37	7.40	1.34	0.39	5.50	1.64	7.29	15.97	
3"	mm	72.9	226.0	38.0	10.0	160.0	48.2	192.4	401.0	M10x(12mm)
	inch	2.87	8.90	1.50	0.39	6.30	1.90	7.57	15.79	
4"	mm	97.38	252.0	45.0	12.0	200.0	61.5	210.8	619.0	M16x(18mm)
	inch	3.38	9.92	1.77	0.47	7.87	2.42	8.30	24.37	

R48 series surface finish

R48 series surface, which comes directly or indirectly in contact with the product are machined to Ra 25 Max as standard. Mechanical polishing to higher levels of surface finish up to Ra 15, are available.

FLUSH TANK BALL VALVES

R47P&R48 SERIES

HABONIM standard flush tank plate will fit most tank configurations, such as dished, flat, ellipsoidal, jacketed, conical or spherical.

For special applications **HABONIM** also manufactures adaptor plates, when replacing a conventional flush tank valve with a direct flow, higher Cv, quarter turn, flush tank ball valve.

HABONIM also has the ability to ship the plate independently from the valve, in order to accommodate customer requests.

Technical Summary

Size Range:	½" - 4" (DN15 - DN100)
Port:	Reduced, Full & Tubore.
Sanitary Applications:	Pharmaceutical, Biotechnology, Cosmetics, Food & Beverage
Industrial Applications:	General Service, Petrochemical, Chemical
Pressure Range:	Vacuum 10 ⁻⁶ torr up to 50 bar (700 psi)
Temperature Range:	-80°C to +320°C (-112°F to +608°F)
Materials:	Stainless Steel, Hastelloy-C, Alloy-20, Monel, Duplex.
Downstream End Connection:	Screwed, Socket or Butt weld, Flanged, Tri-Clamp, ETO (Tubing)
Operation:	Hand operated, Pneumatic or Electric Actuated.
Standard of compliance:	ASME Boiler & pressure code, Section 8 - Division 1 Tank bottom flange, ANSI B16.11, B16.25, B16.34, B31.1, B31.3, ASME BPE
Certification:	ISO 9001, CE, ATEX

Welding Instructions

1. With the valve in its open position, remove body connector screws.
2. Separate both the upstream flush tank end and the down stream end.
3. Dispose of the used O-rings seals.
4. Place all components removed in clean secure position, clear of welding splatter.
5. Prepare the vessel port at the desired location according to the outside dimension of the flush tank end.
Remember - it is crucial to have maximum adaptation (minimum gap) between the vessel bore and the flush tank end.
6. Fit the flush tank end to the bottom of the vessel, with the internal surface of the vessel in line with the surface of the flush tank end, Tack weld only. (See figure 1).
7. Protect the sealing surface of the flush tank end from welding splatter and complete welding. Allow enough time for cooling.
8. Flush the tank allowing dirt, welding slag, or any other debris to be flushed through the flush bottom tank end.
9. Replace body seals (replacement package).
10. Lift the complete assembly to engage the flush tank end.
11. Position the screws and turn (2-3 turns) so that complete assembly is connected loosely in place.
12. Tighten the bolts to torque figures (table 1) and according to tightening patterns (Figure 2).
13. Close the valve and run the process.

FIGURE 1

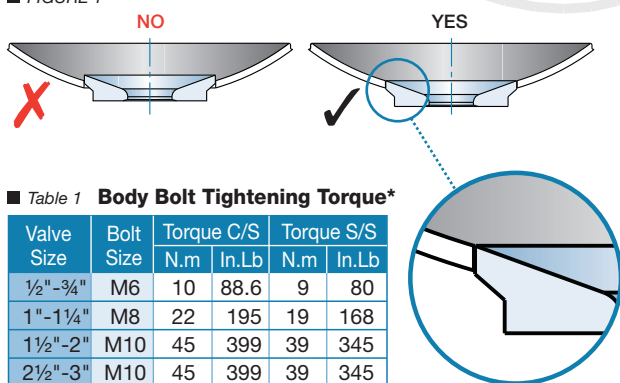

Table 1 Body Bolt Tightening Torque*

Valve Size	Bolt Size	Torque C/S		Torque S/S	
		N.m	In.Lb	N.m	In.Lb
½"-¾"	M6	10	88.6	9	80
1"-1¼"	M8	22	195	19	168
1½"-2"	M10	45	399	39	345
2½"-3"	M10	45	399	39	345
4"	M12	75	665	65	576

* The tightening torques will be according to the bolt size.

47P/48 Series ½"-2½"

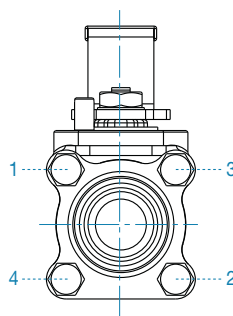
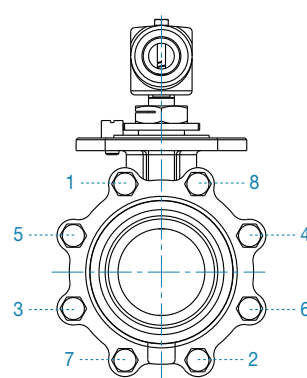

FIGURE 2

47P/48 Series 3"-4"



For ordering information refer to Bulletins P-111 & P-140

In accordance with our policy to strive for continuous improvement of the product, we reserve the right to alter the dimensions, technical data and information included in this catalogue when required.



Headquarters Habonim ISRAEL
Tel: +972-4-6914911, Fax: +972-4-6914902
sales_international@habonim.com

ISRAEL
Tel: +972-4-6914903
Fax: +972-4-6914935
sales_israel@habonim.com

www.habonim.com

North America
Toll Free Phone: 1-866-261-8400
Toll Free Fax: 1-866-243-9959
sales_usa@habonim.com

Europe
Habonim Europe
Tel: +972-4-6914733
Fax: +972-4-6914703
sales_europe@habonim.com

U.K.
Habonim UK
Tel: +44-1633-484554
Fax: +44-1633-482252
sales@habonimuk.com

China
Habonim China
Tel: +86 21 5219 1139
Fax: +86 21 5219 3780
sales_china@habonim.com.cn