

HABONIM

47X Series

Installation, Operating & Maintenance

3-Piece Ball Valves

Series Included:

47X, B47X

Sizes Included:

1/4" - 6" (DN6 - DN150)

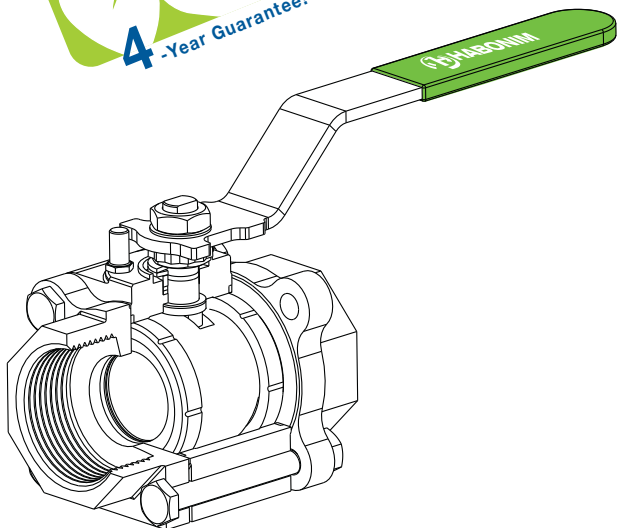

1. GENERAL

This Installation, Operating & Maintenance manual covers the instructions required for safe use of Habonim 3-piece ball valves type 47P series. The manual relates to reduce bore and full bore. Before using a valve, read the entire IOM carefully and make sure you understand everything.

WARNINGS & SAFETY INSTRUCTIONS

Habonim cannot anticipate all of the situations a user may encounter while installing and using Habonim valves. The user **MUST** know and follow all applicable industry specifications on the safe installation and use of these valves. Misapplication of the product may result in injuries or property damage. Refer to Habonim product catalogues, product brochures and installation, operating and maintenance manuals for additional product safety information or contact Habonim.

1. Keep hands and objects away from the valve ports at all times. Actuated valves could be accidentally operated, resulting in serious injury or valve damage.
2. Before removing a valve from the line, always make sure the line has been depressurized and drained. Cycle the valve a few times to relieve any pressure that could be trapped in the body cavity.
3. Utmost caution must be taken when handling a valve that has toxic, corrosive, flammable or a contaminant nature media flowing through its pipeline. The following safety precautions are recommended when dismantling valves with hazardous media:
 - a. Wear eye shield, protective headgear, clothing, gloves and footwear.
 - b. Have available running water.
 - c. Have a suitable fire extinguisher when media is flammable.
4. Do not try to operate a valve that exhibits any sign of leakage. Isolate the valve and either repair or replace it.
5. Do not use or substitute non Habonim components or parts in Habonim valves and assemblies.



Kfar Hanassi, Upper Galilee 12305 Israel
Tel: 972 - 4 - 6914911
Fax: 972 - 4 - 6914902
E-Mail: habonim@habonim.co.il
www.habonim.com

DEDICATED TO INNOVATION

2. LIMITATIONS

The correct selection of materials of construction, seats and seals, internal valve components and pressure/temperature ratings determines the safe use of the valves and the particular performance requirements for the application. This information can be found on the nameplate welded to the valve body.

The combined corrosion and erosion allowance for the valve body wall thickness is 1 mm. When this allowance has gone, the valve should no longer be used. Inspect the valve wall thickness every time the valve is maintained. Refer to Habonim Corrosion Data Chart T-614 to determine the corrosion rate for your application. As the extent of applications these valves can be used in is large, it does not make it possible to cover all installation and maintenance instructions to service the valves. It is the owner's responsibility to use the valves as recommended and in accordance with the pressure and temperature limits as stated in this manual. Where in doubt, please consult with Habonim.

Any unstable fluid or gas should be identified by its manufacturer and must not be used with Habonim valves.

CAUTION:

The valves should be used in a well designed, adequately protected system to **ensure that external and internal pressure and temperature limits are not exceeded**. The valve body rating can be higher than the seat rating. •Valve surface temperature may become extremely hot or cold due to ambient or operating conditions. Prevent any type of direct contact with the valve that may harm the workers. Wear protective gloves.

The valves should be used in a well designed, adequately supported piping system such that it will not be subjected to undue forces and moments during service. Avoid shock loads (water hammer). The valves are not designed to operate during or after earthquakes or under fatigue conditions. It is the responsibility of the owner to determine if fatigue conditions exist.

When gasketing always ensure multiple ground paths across gaskets. i.e. < 1Ω across total gasket.

Do not allow dust layers to build up on the equipment. The process fluid temperature shall not exceed the ignition temperature of the dust.

3. STORAGE

Prior to storage, inspect the valve for shipping damage. Keep all protective packaging, flange covers and end caps attached to the valves during storage. It is recommended to keep the valves in a clean and dry environment until ready for use.

Carbon Steel valves have a "black oxide" and oil dipped finish. This nontoxic process is performed to retard rusting during storage. It is not a substitute for paint or other means of protective coating to be applied to the valve once installed.

Stainless steel valves have their natural finish and do not need any additional protection once installed.

4. OPERATING INSTRUCTIONS

Habonim Valves provide tight shut off when used under normal conditions and in accordance with Habonim's published pressure/temperature chart.

If these valves are used in a partially open (throttled) position, seat life may be reduced. Consult with Habonim for the proper seat material selection.

Valve operation works by operating the valve handle 90° turn anti-clockwise to open, and 90° turn clockwise to close. On manually operated valves the valve is open when the handle or stem flats are parallel with the pipeline and closed when the handle or stem flats are perpendicular to the pipeline.

All standard valves are bidirectional and as such, can be installed for flow in either direction. Valves which are unidirectional will have a flow direction arrow welded to the body and separate assembly instructions. A silicone-based lubricant is applied to assist valve break in. The lubricant, if unacceptable, may be removed by a solvent wash.

If a shut-off valve is installed for end of line service, it must be ensured that it is closed with a blind end connection and the valve is secured against being opened unintentionally.

WARNING: Never look into the valve bore while the valve is in a flowline. Pressure and fluids could escape from the valve causing bodily injury.

To prevent leakage, malfunctions resulting from internal wear or seal degradation, the user must establish a preventive maintenance and inspection program.

This program must include:

- a. Inspection of parts to detect loss of wall thickness which may result in decreased pressure capacity.
- b. Routine replacement of seals and inspection for proper operation.

Valve operating torques as published in the Habonim literature are the normal expected maximum break-away torques. These torques have been confirmed by laboratory testing of each valve under controlled conditions. Highly viscous or abrasive media, frequency of operation and temperature fluctuations could cause an increase in valve torque.

5. INSTALLATION

The installation procedure for ball valves is critical to ensuring both long life and satisfactory performance. Valves stored on site awaiting installation should be kept in their original packing, in dry conditions, where damage will not occur. Before carrying out the installation, it is important to follow the basic procedures described below:

5.1 General

- 5.1.1 Carefully unpack the valve and check valve nameplate for identification of materials (see **Figure 2**).
- 5.1.2 Remove any special materials, which were used for packing.
- 5.1.3 Check the valve for any marks indication flow direction. Appropriate care must be taken, to install the valve for proper flow orientation.
- 5.1.4 Inspect the valve interior through the end ports to determine it is clean and free from foreign matter.
- 5.1.5 Cycle the valve and inspect any functionally significant features.
- 5.1.6 Read all the literature and note any special warning tags or plates attached to the valve.
- 5.1.7 Before installation check to insure the ball is in the fully open position in order to prevent possible damage to the ball and seats. The valve performance depends on its original conditions. At any stage do not leave the valve in the partially open position.

5.2 Threaded End Valves

- 5.2.1 Valves with screwed ends should be treated as a single unit and should not be dismantled when installing to pipeline.
- 5.2.2 Before installing the valves, make sure that the threads on the mating pipe are free from excessive grit, dirt or burrs.
- 5.2.3 When tightening the valve, apply a pipe wrench or spanner to the end connector closest to the pipe being worked, using standard piping practices.
- 5.2.4 Use appropriate joining sealants material in correct quantities.
- 5.2.5 If "back-welding" is required on screwed valves, refer to the instructions for Weld End valves or to the "Habonim Welding Instructions" bulletin.

5.3 Weld End Valves in-line

- 5.3.1 Welding of valves shall be performed by a qualified person according to the ASME Boiler Construction Code Section IX. For valves to be welded within the EEA, refer to the requirements of ESR 3.1.2 of the Pressure Equipment Directive 97/23/EC.
- 5.3.2 Valves with Delrin® or UHMWPE seats must be disassembled before welding in line. For more information on recommended welding procedures or seat materials, please consult with Habonim.
- 5.3.3 Valves that will be welded directly to the line must be in the fully open position to protect the ball and seats from excessive temperatures during the welding procedures.
- 5.3.4 It is recommended to remove the valve wrench during the welding procedure. Protect or remove actuators from weld splatter or arc strikes. Valves in the "Fail Close" position should be cycled to the open position.
- 5.3.5 Use a temperature stick and a wet cloth wrapped around the center section to prevent overheating. **DO NOT** heat the center section over 150°C (300°F).
- 5.3.6 Align valve to pipe line, ensuring proper fit to minimize pipe load. Tack weld only.
- 5.3.7 Complete welding in small segments. Allow enough time for cooling between each segment.
- 5.3.8 After completing the welds, wait for the valve to cool below 90°C (200°F). Tighten the body bolts to torque figures and tightening patterns according to **Figure 1**.
- 5.3.9 Replace the wrench or actuator. It is recommended not to rotate the valve to the closed position before flushing the line.

5.4 Weld End Valves not in-line

- 5.4.1 Welding of valves shall be performed by a qualified person according to the ASME Boiler Construction Code Section IX. For valves to be welded within the EEA, refer to the requirements of ESR 3.1.2 of the Pressure Equipment Directive 97/23/EC.
- 5.4.2 Valves that will be disassembled before welding carry a packet with replacement body seals. Follow steps 2 to 9 of the DISASSEMBLY section but do not discard the seat rings.
- 5.4.3 Prior to welding the ends to the pipe, make sure their flats are aligned to the body flats (see NOTE in **page 6**).
- 5.4.4 **Do not scratch or cut the seats and sealing surfaces of the valves as this will cause valve leakage.**

- 5.4.5 Assemble the valve without the ball and seats and follow steps 1 to 7 for Weld End Valves.

- 5.4.6 After the valve cools down, follow again steps 2 to 9 of the DISASSEMBLY section and section 7 to 13 of the ASSEMBLY section.

6. MAINTENANCE

HABONIM valves have a long and trouble free life, and maintenance is seldom required. When maintenance is necessary, valves can be refurbished on site.

To extend valve performance and reduce possible plant problems, the following procedures should be followed:

- 6.1 If leakage at the stem is noted, tighten the gland nut about a 1/6-turn as a routine maintenance procedure. This will compensate for any wear or settling of the gland packing.
- 6.2 **Caution:** Excessive tightening of the stem nut can result in accelerated seal wear and high valve operating torque.
- 6.3 If the valve is removed from the line and disassembled, replacement of all seats and seals is recommended using the appropriate Habonim Repair kit. Examine all metallic sealing surfaces such as ball, stem, and the surfaces on the end connectors that contact the seats for wear, corrosion or damage.
- 6.4 Only Habonim's authorized spare parts should be used. Repair kits from Habonim consist of the following:
 - 2 x seat ring
 - 1 x stem packing
 - 2 x stem thrust seal
 - 2 x body seals
- 6.5 In addition to repair kits, other spare parts available from Habonim are: valve balls, stems, glands, bolts, screws and nuts. Should additional parts be required, it is recommended that the complete valve be replaced.
- 6.6 When ordering repair kits, please provide the valve size and full figure number code and series.

7. DISASSEMBLY

The following instructions are for in-line disassembly of valves sizes 1/2" to 2 1/2" (or 2" full bore).

- 7.1 Cycle the valve with the line pressure fully relieved before attempting to remove the valve from the pipeline, to insure pressure has also been discharged from the valve cavity.
- 7.2 Bring the valve handle to the open position. **Warning:** trying to remove the valve body from the line in the closed position will damage the ball.
- 7.3 With the valve in the open position, loosen all 4 body bolts.
- 7.4 Remove all but one body bolt, so the valve body can swing away from its installed position and be brought out of the pipe line (see **figure 3**).
- 7.5 If it is required to completely remove the body, remove the last bolt and bring out the body center section.
- 7.6 Swing out the body from between the end connectors.
- 7.7 Remove and discard the seat rings and body seals. Be careful not to damage the sealing surfaces.

- 7.9 Support the ball to prevent it from falling out of body and turn handle to the closed position for its removal. Set the ball aside in clean secure area for reuse.
- 7.10 Remove the handle nut, serrated washer, handle, locking clip, stem nut, disk springs and follower. Place all components removed, in clean secure area.
- 7.11 Push the stem down into the body and remove it. Discard the stem thrust seal, bearing and packing, care taken not to scratch or nick the stem bore area of the body. Clean the stem and stem bore area.

The following instructions are for in-line disassembly of valves sizes 3” to 6”.

- 7.12 Cycle the valve with the line pressure fully relieved before attempting to remove the valve from the pipeline, to insure pressure has also been discharged from the valve cavity.
- 7.13 Bring the valve handle to the open position. **Warning:** trying to remove the valve body from the line in the closed position will damage the ball.
- 7.14 With the valve in the open position, loosen all body bolts. Some valves have 8 through bolts and nuts and some have 16 bolts (8 on each side) screwed to the body.
- 7.15 Remove all body bolts and bring out the body center section.
- 7.16 Locate the side of the body that has the seat retaining ring. Support the ball from that side to prevent it from falling out of body and turn handle to the closed position for its removal. Set the ball and seat retaining ring aside in clean secure area for reuse. Remove and discard the seat rings and body seals. Be careful not to damage the sealing surfaces.
- 7.17 Remove the wrench bolt, wrench head and handle, stem nut, stop plate and follower. Place all components removed, in clean secure area.
- 7.18 Push the stem down into the body and remove it. Discard the stem thrust seal, bearing and packing, care taken not to scratch or nick the stem bore area of the body. Clean the stem and stem bore area.

8. ASSEMBLY

The following instructions are for in-line assembly of valves sizes 1/2” to 2 1/2” (or 2” full bore).

- 8.1 Lubricate the new stem thrust seal, bearing and packing, with appropriate lubricant (Molykote 33 - thin smear). Place the stem thrust seal on the stem.
- 8.2 Insert the stem horizontally into the center body with the threaded side first and carefully guide it up through the stem bore.
- 8.3 Holding the stem up insert the new packing over the stem and into the stem bore. Place the bearing, follower and two disk springs onto the stem. The first spring convex side down and the second spring convex side up.
- 8.4 Thread the stem nut onto the stem. Tighten the stem nut to the torque figures (**table 1**).
- 8.5 Place the locking clip on the stem nut by adjusting the orientation of the nut (in the clockwise direction).

- 8.6 Place the handle, serrated washer and thread the handle nut on the stem. Holding the handle tighten the handle nut tight.
- 8.7 Bring the handle to the closed position to insert the ball.
- 8.8 Place the ball in the center body until the stem tongue is engaged and bring the valve to the open position to prevent the ball from falling out.
- 8.9 Place the new body seals and new seat rings in the body.
- 8.10 Ease back the body assembly between end connectors, taking care not to score faces or damage seals, and reinstall body bolts and nuts.
- 8.11 To prevent galling of threads of bolts or nuts, lubricate threads with an anti-galling compound.
- 8.12 Tighten the body bolts to the torque figures (**table 2**), and according to tightening pattern illustrated in **figure 1**.
- 8.13 Leave the valve in the open position for flushing the line.

The following instructions are for in-line assembly of valves sizes 3” to 6”.

- 8.14 Lubricate the new stem thrust seal, bearing and packing, with appropriate lubricant (Molykote 33 - thin smear). Place the stem thrust seal on the stem.
- 8.15 Insert the stem horizontally into the center body with the threaded side first and carefully guide it up through the stem bore.
- 8.16 Holding the stem up insert the new packing over the stem and into the stem bore. Place the bearing, follower and stop plate onto the stem
- 8.17 Thread the slotted gland nut onto the stem. Tighten the gland nut to the torque figures (**table 1**).
- 8.18 Place the wrench head on the stem making sure it is parallel to the stem groove for ball valve position. Insert the handle through the wrench head and tighten with the wrench bolt,
- 8.19 Bring the handle to the closed position to insert the ball.
- 8.20 Place the ball in the center body until the stem tongue is engaged and bring the valve to the open position to prevent the ball from falling out.
- 8.21 Place the new body seat rings, seat retaining ring and new body seals in the body.
- 8.22 Ease back the body assembly between end connectors, taking care not to score faces or damage seals, and reinstall body bolts and nuts.
- 8.23 To prevent galling of threads of bolts or nuts, lubricate threads with an anti-galling compound.
- 8.24 Tighten the body bolts to the torque figures (**table 2 or 3**), and according to tightening sequence illustrated in **figure 1**.
- 8.25 Leave the valve in the open position for flushing the line.

TABLE 1
Stem Nut Tightening Torque

Reduce Bore	Full Bore	Nut Thread	*HermetiX Seals	
			Nm	in.lb
1/4", 3/8", 1/2"		3/8"-24 UNF	4	35
3/4"	1/2"	3/8"-24 UNF	4	35
1	3/4"	7/16"-20 UNF	9	80
1 1/4"	1	7/16"-20 UNF	9	80
1 1/2"	1 1/4"	9/16"-18 UNF	13	115
2"	1 1/2"	9/16"-18 UNF	13	115
2 1/2"	2"	9/16"-18 UNF	13	115
3"	2 1/2"	1"-14 UNS	60	530
4"	3"	1"-14 UNS	60	530
6"	4"	1 1/2"-12 UNF	120	1060

* These torque figures are applicable on Carbon Filled PTFE(NRG) and TFM seals.

IMPORTANT:

An excessively tightened stem nut can cause excessive packing wear and increase stem torque.

TABLE 2
Body Bolt Tightening Torque

Reduce Bore	Full Bore	Bolt Thread	tightening torque	
			Nm	in.lb
1/4", 3/8", 1/2"		M6	9	80
3/4"	1/2"	M6	9	80
1	3/4"	M8	18	160
1 1/4"	1	M8	18	160
1 1/2"	1 1/4"	M10	39	345
2"	1 1/2"	M10	39	345
2 1/2"	2"	M10	39	345
3"	2 1/2"	M10	39	345
4"	3"	M12	65	575
	4"	M16	160	1420
6"		M20	300	2655

FIGURE 1
Body Bolt Tightening Pattern

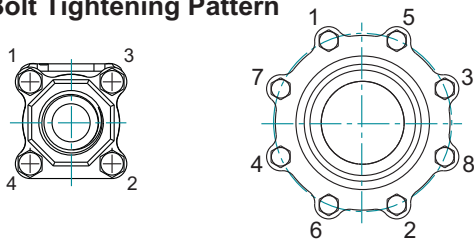

Sizes 1/4" - 2 1/2"

Sizes 3" - 6"

FIGURE 2
Valve Marking and Labeling

All valves marking is on a nameplate which is spot welded to the valve body. Valves for the European market and above 1" carry the CE mark with the information required by the PED.

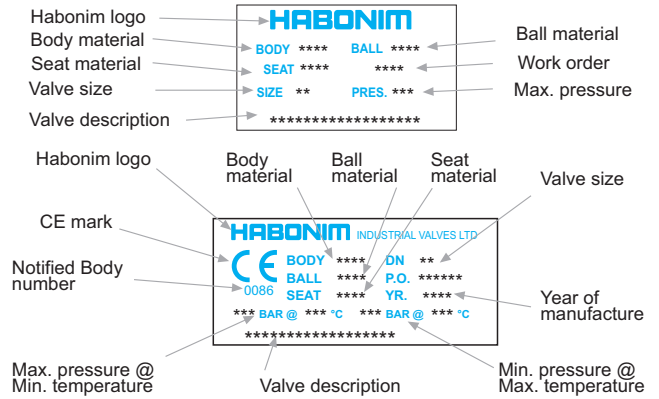
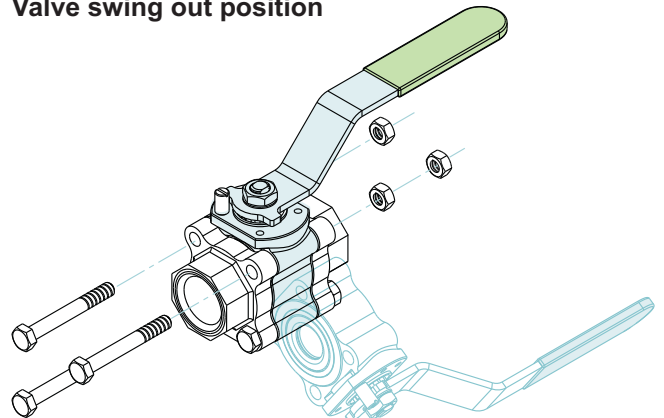

FIGURE 3
Valve swing out position



The 3-piece ball valves are in-line repairable. Prior to servicing the valve, bring it to the open position making sure to release line pressure and drain all trapped media from the valve cavity. Keep the valve in the open position and remove all but one body bolt, so the valve body can swing away from its installed position and be brought out of the pipe line. In this position it is easy to replace all internal parts and then swing the body back to its original position. If it is required to completely remove the body, remove the last bolt and bring out the body center section.

Habonim reserves the right to change design features without prior notice.

DELRIN® is a registered trademark of DuPont.
TFM™ is a trademark of Dyneon.

47X SERIES STANDARD VALVE

SIZES: 1/2"-2 1/2" RB, 1/2"-2" FB

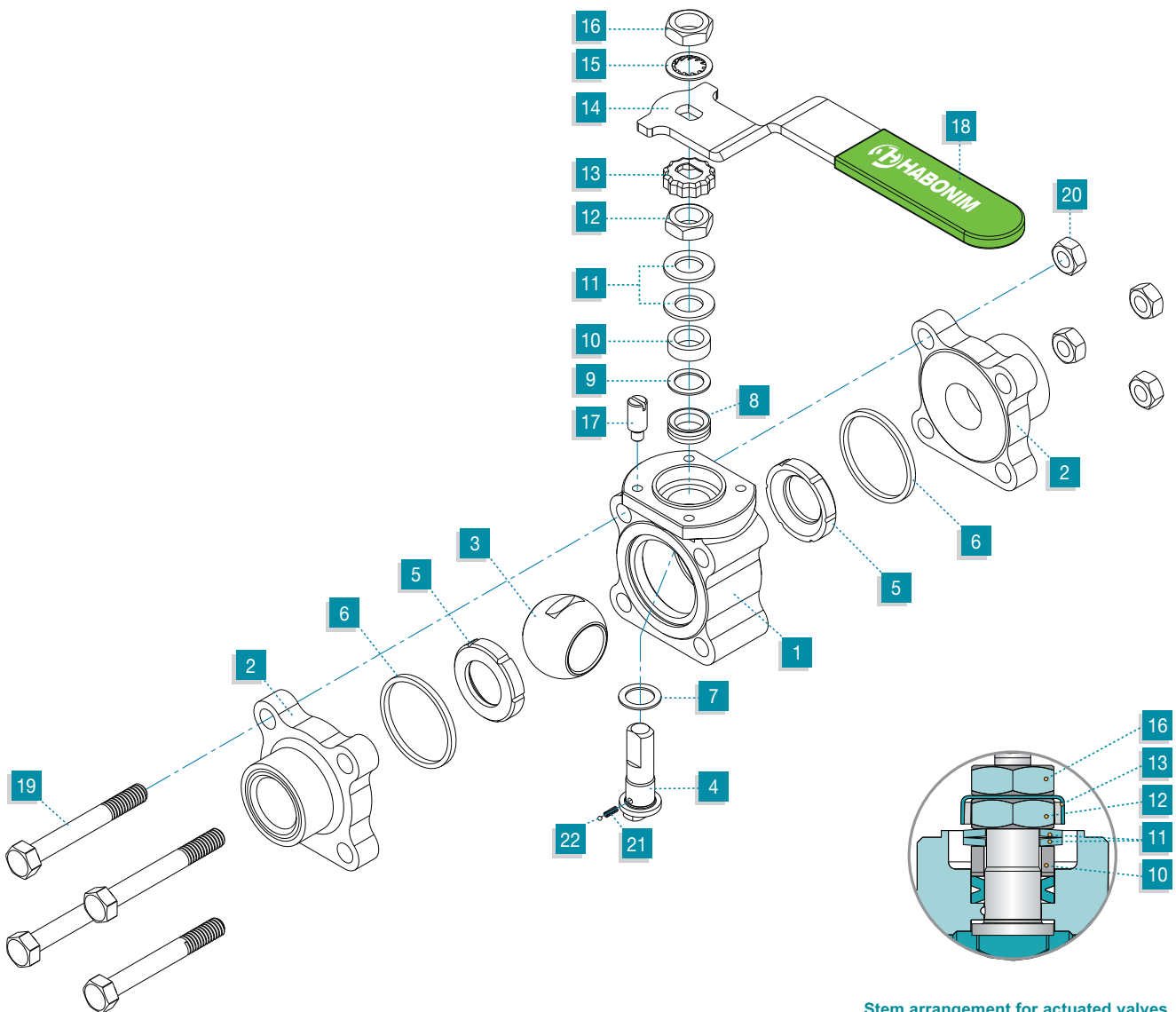

Stem arrangement for actuated valves.

Release the handle nut **16** and serrated washer **15** remove the handle **14** and refasten the nut **16** on the locking clip **13**. 1/2" & 3/4" Valves do not require the nut **16**.

Material Specifications

Item	Description	Material Specifications	Qty.
1	Body	Stainless St. ASTM A351 CF8M, Carbon St. ASTM A105, WCB, Hasteloy C, Hasteloy C22, Alloy 20, Monel, Duplex, Super Duplex	1
2	End connector	Stainless St. ASTM A351 CF3M, Carbon St. ASTM A105, WCB, Hasteloy C, Hasteloy C22, Alloy 20, Monel, Duplex, Super Duplex	2
3	Ball	Stainless St. ASTM A351 CF8M, Hasteloy C, Hasteloy C22, Alloy 20, Monel, Duplex, Super Duplex	1
4	Stem	Stainless St. ASTM A276 316/316L, Hasteloy C, Hasteloy C22, Alloy 20, Monel, Duplex, Super Duplex	1
5	Seat ring	PTFE, RPTFE, NRG, PEEK, TFM, VESPEL, DELRIN, UHMWPE	2
6	Body seal	PTFE, RPTFE, TFM, UHMWPE, Graphite, Metal O-Ring	1
7	Stem thrust seal	PEEK	1
8	Gland packing	NRG, TFM	1

Item	Description	Material Specifications	Qty.
9	Bearing	PEEK	1
10	Gland	Stainless St. ASTM B783 316L	1
11	Disc spring	Stainless St. 17/7-PH	2
12	Gland nut	Stainless St. ASTM A194 316	1
13	Locking clip	Stainless St. ASTM A164 304	1
14	Handle	S. ST ASTM A240 430, Carbon St. Zinc plated	1
15	Serrated washer	Stainless St. 410	1
16	Handle nut	Stainless St. ASTM A194 316	1
17	Stop pin	Stainless St. ASTM A582 303	1
18	Handle sleeve	Vinyl plastisol	1
19	Body bolt	Stainless St. ISO 4014 A2-70 Carbon St. ISO 4014 GR 8.8 zinc plated	4
20	Body nut	Stainless St. ISO 4034 A2-70 Carbon St. ISO 4034 GR 8.8 zinc plated	4
21	Anti static spring	Stainless St. AISI 302	1
22	Anti static ball	Stainless St. AISI 304	1

47X SERIES STANDARD VALVE

SIZES: 3"-6" RB, 2½"-4" FB

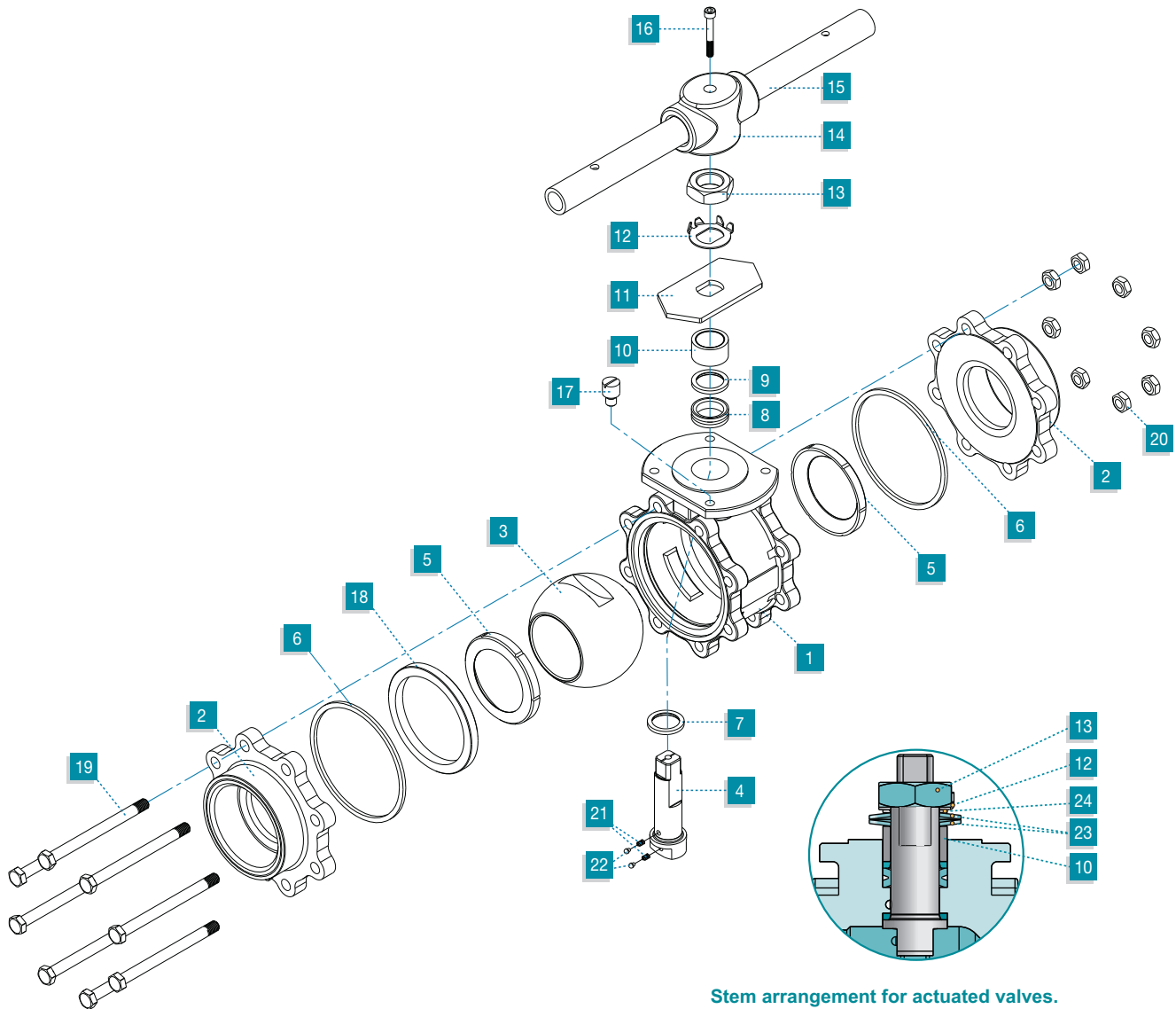

Stem arrangement for actuated valves.

Release the wrench bolt **16** and remove the wrench handle **15**, the wrench head **14**, the gland nut **13**, tab lock washer **12** and stop plate **11**. Assemble the two disc springs **23**, location ring **24**, tab lock washer **12**, and refasten the gland nut **13**.

Material Specifications

Item	Description	Material Specifications	Qty.
1	Body	Stainless St. ASTM A351 CF8M, Carbon St. ASTM A216 WCB	1
2	End connector	Stainless St. ASTM A351 CF3M, Carbon St. ASTM A216 WCB	2
3	Ball	Stainless St. ASTM A351 CF8M	1
4	Stem	Stainless St. ASTM A276 316/316L	1
5	Seat ring	PTFE, RPTFE, NRG, PEEK, TFM, VESPEL, DELRIN, UHMWPE	2
6	Body seal	PTFE, RPTFE, TFM, UHMWPE, Graphite, Metal O-Ring	1
7	Stem thrust seal	PEEK	1
8	Gland packing	NRG, TFM	1
9	Bearing	PEEK	1
10	Gland	Stainless St. ASTM B783 316L	1
11	Stop plate	Stainless St. ASTM A240 430, Carbon St. ST37 Zinc Plated	1

Item	Description	Material Specifications	Qty.
12	Tab lock washer	Stainless St. ASTM A240 304	1
13	Gland nut	Carbon St. Zinc Plated	1
14	Wrench head	ASTM A47 Maleable Iron	1
15	Wrench handle	Stainless St. 304 Carbon St. Zinc Plated	1
16	Wrench bolt	Stainless St. ISO 4014 A2-70	1
17	Stop pin	Stainless St. ASTM A582 303	1
18	Seat Retaining Ring	Stainless St. ASTM A351 CF8M Carbon St., WCB	1
19	Body bolt	Stainless St. ISO 4014 A2-70 Carbon St. ISO 4014 GR 8.8 zinc plated	8
20	Body nut	Stainless St. ISO 4034 A2-70 Carbon St. ISO 4034 GR 8.8 zinc plated	8
21	Anti static spring	Stainless St. AISI 302	2
22	Anti static ball	Stainless St. AISI 304	2
23	Disc Spring	Stainless St. 17/7-PH	2
24	Location Ring	Stainless St. A164 304	1